

---

## Design of quality system documentation in hydrotiller production unit as improvement of quality management system in small and medium enterprise

---

Nilda Tri Putri\* and Frastia Retha

Department of Industrial Engineering,  
Faculty of Engineering,  
Andalas University, Indonesia  
Email: nilda@ft.unand.ac.id  
Email: rewarau@gmail.com  
\*Corresponding author

Shari Mohd Yusof

Department of Manufacturing and Industrial Engineering,  
Faculty of Mechanical Engineering,  
Universiti Teknologi Malaysia, Malaysia  
Email: shariyusof@gmail.com

**Abstract:** CV Citra Dragon is one of small and medium industries producing equipment and agricultural machinery (also known as *Alsintan*) in West Sumatra, Indonesia. CV Citra Dragon needs to implement a quality management system (QMS) to win the competition as a result of globalisation. Implementing QMS based on ISO 9001 are important in helping *Alsintan* become more competitive. QMS applied in CV Citra Dragon is still limited to a single product that is rice thresher machine (thresher). Therefore, the scope of the quality management system in the company needs to be extended to other products that are hydrotiller or tractor turtle which is one of the two main products produced by CV Citra Dragon. QMS is a set of documented procedures and standard practices for the management system that aims to ensure compliance with the requirements of the process and the products that have been set. The existence of a well-documented quality system is important for a company or organisation in implementing quality management systems. Therefore, it is necessary to design a quality system documents on CV Citra Dragon related to hydrotiller production process. The design of quality system documents in this research is based on the ISO 9001: 2008. Quality systems documents are required and made in the study include three levels of documentation, the procedures, work instruction, and form.

**Keywords:** quality management systems; QMSs, ISO 9001:2008; procedures; work instructions; forms; small and medium enterprises; SMEs.

**Reference** to this paper should be made as follows: Putri, N.T., Retha, F. and Yusof, S.M. (xxxx) 'Design of quality system documentation in hydrotiller production unit as improvement of quality management system in small and medium enterprise', *Int. J. Productivity and Quality Management*, Vol. X, No. Y, pp.xxx-xxx.

**Comment [A1]:** Author: Please confirm if N.T. Putri is the corresponding author.

**Comment [A2]:** Author: Please reduce abstract (should be up to 150 words only).

**Biographical notes:** Nilda Tri Putri is a Senior Lecturer in Department of Industrial Engineering, Faculty of Engineering, Andalas University, Padang, Indonesia. She received her Doctor of Philosophy (PhD) from Department of Manufacturing and Industrial Engineering, University Technology Malaysia in 2011. Her research interests include quality engineering, quality control, and total quality management.

This paper is a revised and expanded version of a paper entitled [title] presented at [name, location and date of conference].

**Comment [A3]:** Author: Please provide the biographical details of no more than 100 words for F. Retha and S.M. Yusof.

**Comment [A4]:** If a previous version of your paper has originally been presented at a conference please complete the statement to this effect or delete if not applicable.

## 1 Introduction

Quality management system (QMS) is a set of documented procedures and standard practices for the management system that aims to ensure compliance with the requirements of the process and the products that have been set. According to Goetsch and Davis (2002),

“a quality management system (QMS) consists of all the organization’s policies, procedures, plans, resources, processes, and delineation of responsibility and authority, all deliberately aimed at achieving product or service quality levels consistent with customer satisfaction and the organization’s objectives. When these policies, procedures, plans, etc. are taken together they define how the organization works and how quality is managed.”

The ISO 9000 standard is the most well-known and widely used method for implementing QMS (Rawahi and Bashir, 2011; Ilkay and Aslan, 2012; Bewoor and Pawar, 2010; Devpura et al., 2014). Devpura et al. (2014) revealed that ISO standard is the most popular quality improvement approach. They conducted an exploratory case study in India’s leading marble mining company. Ilkay and Aslan (2012) believed that it is important to ensure a continuous and standardised approach to the concept quality.

ISO 9000 standards provide a company with well-documented procedures to follow in providing goods and services. In order to guarantee product quality, ISO 9000 can be implemented in any kind of organisation regardless of its size, product, or sector. Casalino et al. (2012) argued that the introduction of suitable standards is considered to be a strategic asset for small and medium enterprises (SMEs). There are some previous

researches in relation with the implementation of QMS in SMEs conducted by previous researchers in various countries (Sun and Cheng, 2002; Singh and Singh, 2010; Bewoor and Pawar, 2010; Ashrafi and Bashir, 2011; Ilkay and Aslan, 2012). However, the lack of studies was conducted in this field on SMEs in Indonesia especially in *Alsintan* Company.

Sun and Cheng (2002) revealed that the main reasons for SMEs implementing ISO 9000 are due to market and customer demand or external pressure rather than internal initiation. Their research is based on a survey of 180 Norwegian manufacturing companies. They believed that ISO certifications are crucial in responding to market and customer requirements, but the certification itself does not have much implication for quality and performance. According to Dwi et al. (2012), the implementation of QMS in era of globalisation has a significant role in SMEs to improve competitiveness. By implementing the ISO 9000 QMS, SMEs can provide assurance about the quality consistency as demanded by consumers and can increase efficiency in the production process because it can minimise failure in producing the product (Sinaga, 1998). In addition, the higher level of quality management implementation will affect positively on the financial and non-financial performance (Pandjaitan et al., 2011).

Currently, CV Citra Dragon has implemented a QMS that refers to the requirements in the international standard ISO 9001: 2008 and Indonesian National Standard or also known as *Standar Nasional Indonesia* (SNI) for products standard. The scope of the QMS that implemented in *Alsintan* production process is limited to one type of product, rice thresher machine type straw thrower (thresher). Since it only focused on one product only, there is a need to extend the QMS to other products that is hydrotiller. Hydrotiller also called tractor turtle is one of the two main products produced by CV Citra Dragon. Only general documents exist for the hydrotiller production, and there are no specific documents related to hydrotiller.

The existence of a well-documented quality document is important for a company or organisation in implementing QMSs. A documented quality system aims to ensure compatibility between the process and the product of the particular needs or requirements. Besides, good quality system documentation can increase customer trust on the consistency of product quality. Recognising the importance of the application of quality management for SMEs to compete with other firms, it is necessary to design a quality system documents for implementing QMS to fulfil SNI certification. The purpose of this study is designing QMS documents, the standard operating procedures (SOPs), work instructions (WIs), and documents for records (form) for *Alsintan* SMEs to help the company achieved ISO certification and SNI certification as well.

## 2 Stages in preparation of quality system document in SMEs

Steps are being taken in preparing and developing the quality system documents in this study includes three main phases, namely the evaluation of the initial conditions, the determination of document needs, and develops quality system documents. In the first stage, the information about the entire processes in the company are collected that includes the type of processes, input and output processes, workflow and interaction between processes, in charge of the process, making the business process, and each activity in the process. In the second stage, the required document determined by

analysing business processes and activities in each process based on the quality system standards used. At the final stage, the preparation of quality documents done by identifying the sequence of a job, the person in charge of the work, and determine the need to do a recording of a job. The implementation of a QMS consists of the following steps as shown in Figure 1.

**Figure 1** Stages of preparation quality system document for SMEs

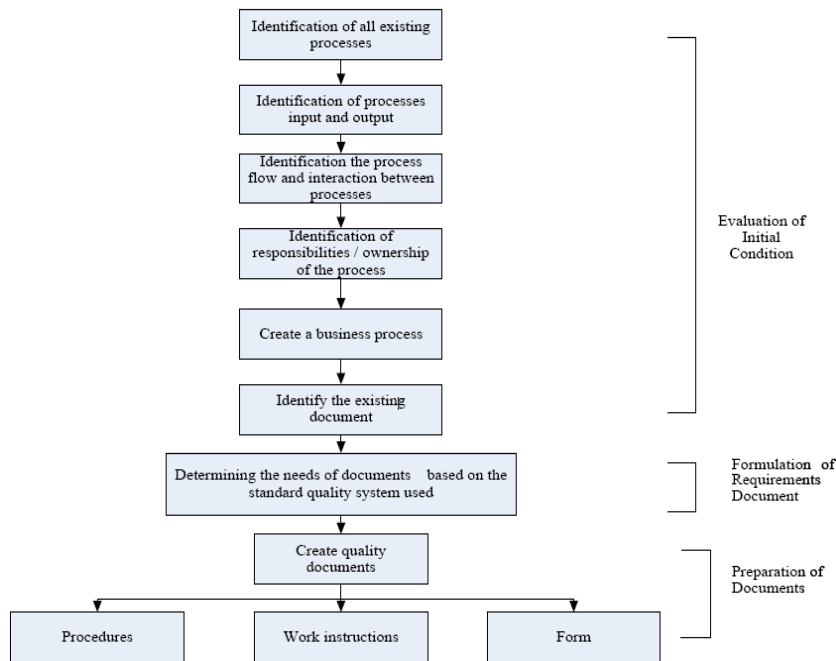

### 3 Evaluation of initial conditions

CV Citra Dragon has implemented a QMS based on the international standards, ISO 9001: 2008, in carrying out its activities in producing *Alsintan*. The scopes of the QMS are covering management of main processes and supporting processes. Financial management is not included in the QMS. Figure 2 shows the interaction between the process and the main process illustrating the processes that are directly related to the product. Therefore, to expand the scope of the QMS in product hydrotiller will require creating a QMS documents relating to the main process.

Processes that exist in CV Citra Dragon consist of the main processes, supporting processes, and policies. There are six main processes, namely marketing, planning, purchasing, quality control (QC) and quality assurance (QA), production, warehouse and shipping/transportation. The activities of marketing process are receiving customer demand, receiving customer complaints, and measuring customer satisfaction. The

activity of planning process is to plan production based on demand from consumers. The activities of purchasing process are: make purchasing order, receive raw materials, verify the raw materials, return the raw materials to suppliers if the material does not fulfil the specifications, and supplier evaluation. The activities of QA/QC process are inspections of raw materials, inspection of semi-finished products, inspections of finished product/final, design and development of products, and identification of the product. The activities of production process are establishing design and development stages, producing products, and perform rework on a product that does not meet specifications. The activities of warehouse and delivery process are store raw materials, store the finished product, and product delivery.

**Figure 2** Interaction between process CV Citra Dragon

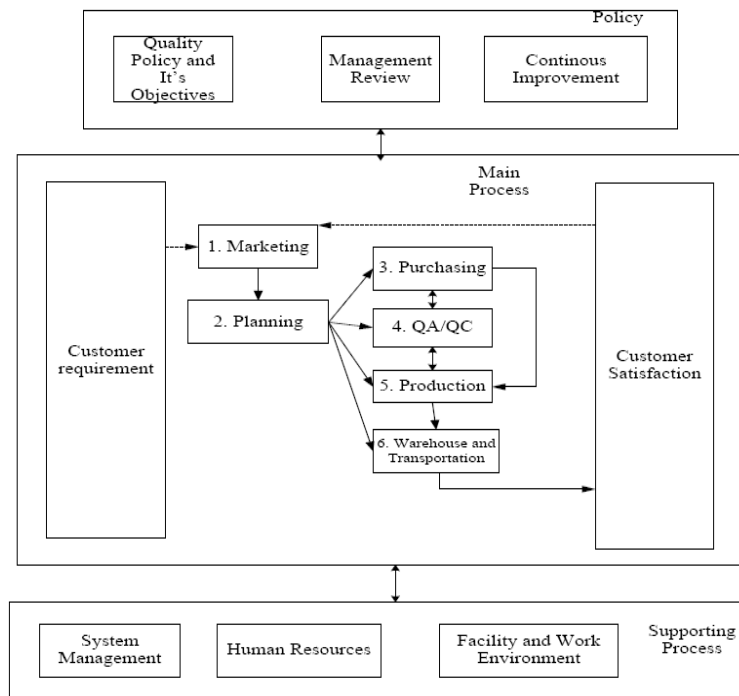

Source: CV Citra Dragon

#### 4 Formulation of requirements document

The required quality documents can be seen in the business process CV Citra Dragon in Figure 3. Based on the business process, it can be seen that the document needs to be prepared for hydrotiller related major processes and fulfilment requirements of the clauses of ISO 9001: 2008 can be seen in Table 1.

Figure 3 Business process CV Citra Dragon

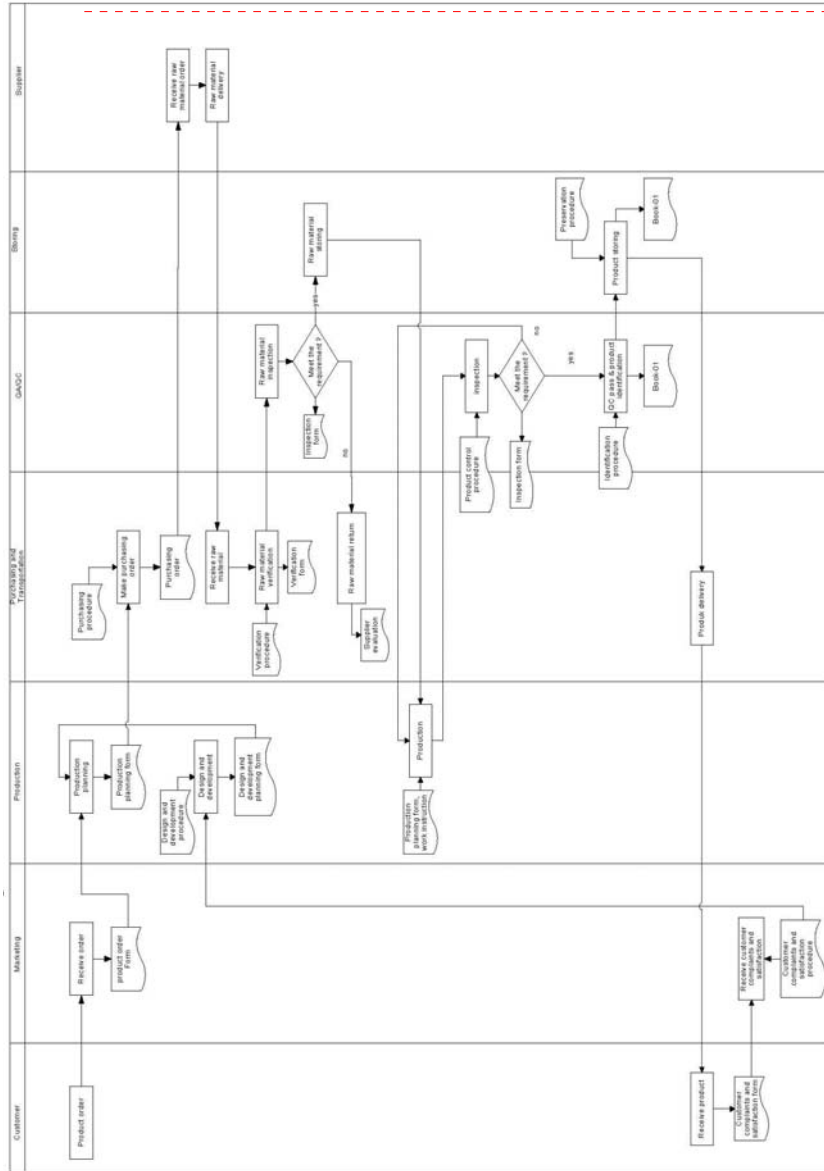

Comment [A5]: Author: Please provide clearer and readable version of this figure preferably EPS file.

**Table 1** List of requirements document

<i>Clause</i>	<i>Main processes</i>	<i>Existing document</i>	<i>Documents required</i>
7.1 Planning of product realisation	Planning	Production planning for <i>tresher</i>	Production planning for <i>hydrotiller</i>
7.3 Design and development	Planning	Tresher product design and development stages	Hydrotiller product design and development stages
7.4 Purchasing	Purchasing	Raw material purchasing information for <i>tresher</i>	Raw material purchasing information for <i>hydrotiller</i>
7.5 Production and service provision	Production QA/QC, storing, and delivery	Tresher production process control, <i>tresher</i> identification and traceability, and <i>tresher</i>	Hydrotiller production process control, <i>hydrotiller</i> identification and traceability
8.2 Monitoring and measurement	Marketing customer satisfaction and feed back	Customer satisfaction measurement for <i>tresher</i> and customer complaints	Customer satisfaction measurement for <i>tresher</i> and customer complaints

## 5 Preparation of documents

### 5.1 Procedure

The procedures established in this study, are arranged based on the structure and format specified in ISO/TR10013: 2008 guidance in making QMS documentation. The procedures consist of the title, purpose, scope, references, definitions, responsibilities, descriptions of activities and related documents. Naming and numbering the procedure is done by following the rules of naming and numbering of existing procedures such as 'product realisation procedure' (PRP) for the procedures relating to the product procurement process, 'management system procedure' (MSP) for procedures relating to management activities, and 'resources procedure' (RP) for the procedures related to resource management.

The procedure prepared were design and product development procedure, supplier evaluation procedure, purchasing procedure, raw material verification procedure, production process control procedure, procedure for the identification and traceability of products, preservation procedure, and customer satisfaction survey procedure. These procedures are based on the processes that have been running in CV Citra Dragon. The example of procedures that made can be seen in Appendix A.

**Table 2** Summary of documents created

<i>ISO clause</i>	<i>2nd level document</i>	<i>3rd level document</i>	<i>4th level document</i>	<i>Other document</i>
7.1 Planning of product realisation	-	-	-	<i>Quality plan</i>
7.3 Design and development	Design and development procedure Planning and production process procedure	Work instruction of hydrotiller production	Hydrotiller design and development form Hydrotiller evaluation and validation design Hydrotiller production planning form	-
7.4 Purchasing	Purchasing of raw material Purchasing procedure Material receiving procedure	-	Supplier evaluation form List of supplier <i>Purchasing order</i> Material verification sheet	-
7.5 Production and service provision	Production process control procedure Identification and traceability procedure Products preservation procedures	-	Material inspection sheet Production process inspection sheet	- Book-01 identification and product delivery
8.5 Monitoring and measurement	Customer satisfaction measurement procedures Customer complaints handling procedures	-	Customer satisfaction measurement form Handling customer complaints form	-



### *5.2 Work instruction*

WIs are detailed descriptions on how to perform and record the work. WIs were developed from the operational activities and hydrotiller production process. The prepared WIs of hydrotiller state the objectives, scope of work with reference to other related documents, the person in charge, the necessary raw materials, machinery and equipment used, and a description of the process of making hydrotiller. Naming the work is done by following the instructions naming rules of existing WIs, namely, work instructions product realisation (WIRP). The numbering follows the numbering done WIs WIRP manufacture of thresher and add a number 03 to distinguish between thresher and hydrotiller thus become 'WIRP02.03 manufacture of hydrotiller'. The example of WI that made can be seen in Appendix B.

### *5.3 Form*

Forms were designed to record the results achieved or as evidence to show that an activity in a documented procedure has been executed. Therefore, the naming and numbering recording form refers to the related documented procedures. For example, the procedure 'PRP 01.02 design and development procedure' is related to the recording form 'PRF 01.02.01 planning of hydrotiller design and development' and 'PRF 01.02.02 evaluation and validation of hydrotiller design and development'. The example of form that made can be seen in Appendix C. Summary of procedures have been designed in this research can be seen in Table 2.

## **6 Conclusions**

This paper has explained the development of QMS documents for hydrotiller production unit. The QMS documents required in the hydrotiller production unit are for the second, third, and fourth level document including procedure, WI, and form. Preparation of these documents is based on existing requirements in the clause of ISO 9001: 2008 QMS standards as used. Making these documents can help in certification of SNI for hydrotiller. The next stage will involve CV Citra Dragon implementing the QMS document that was developed in this research to expand the scope of their QMS.

Future studies should assess the performance of the QMS implemented in CV Citra Dragon by evaluating the fulfilment of ISO 9001: 2008 requirements with the actual practice. It is hoped that the system will be of great benefit for this medium sized company and for other companies to follow suit.

## **Acknowledgements**

The authors would like to acknowledge the financial support provided by Andalas University through BOPTN fund No. 02/UN.16/PL/API/2014.

## References

- Amitava, M. (1998) *Fundamental of Quality Control and Improvement*, 2nd ed., Prentice Hall, New Jersey.
- Ashrafi, R. and Bashir, H.A. (2011) 'Implementation of quality management in organisations operating in the Sultanate of Oman: ISO 9001:2000 vs. non-ISO 9001:2000 certified organisations', *Int. J. of Productivity and Quality Management*, Vol. 7, No. 2, pp.183–201.
- Badan Standarisasi Nasional (2008) *ICS.03.120.10*, Jakarta.
- Bakhtiar, A. and Syakhroni, A. (2005) 'Process documentation in injection molding machine assembly unit as preparation of quality management system ISO 9001: 2000 implementation (case study in PT. XYZ)', *Transistor*, Vol. 5, No. 2, pp.46–59.
- Bewoor, A.K. and Pawar, M.S. (2010) 'An empirical study of the motives and benefits of QMS/ISO implementation among Indian SMEs', *Intl. J. of Productivity and Quality Management*, Vol. 6, No. 3, pp.379–406.
- Casalino, N., D'Atri, A. and Braccini, A.M. (2012) 'A quality management training system concerning ISO standards for sustainable organizational change in SMEs', *Int. J. of Productivity and Quality Management*, Vol. 9, No. 1, pp.25–45.
- CV Nugraha Chakti Consultant (2012) *Preparation of Action Plan for Development of Agricultural Equipment Leading Industry in West Sumatera, Padang*.
- Devapura, M., Reyes, J.A.G., Kumar, V., Lona, L.R. and Meier, H.S. (2014) 'Exploring the application of quality improvement programmes and ISO standards in the Indian marble mining sector', *Int. J. of Productivity and Quality Management*, Vol. 13, No. 3, pp.310–328.
- Dwi, C.K.S., Agustina, L. and Carolina, V. (2012) 'Theoretical study of the quality management system in small and medium enterprises facing the challenges of globalization', *4th National Seminar and Call for Papers Indonesia Management Forum: 'Indonesia Family Business Sustainability*, Ina Garuda Hotel, Yogyakarta, 13–14 November.
- Garvin, D. (1988) *Managing Quality the Strategic and Competitive Edge*, The Free Press, New York.
- Goetsch, D. and Davis, S. (2002) *Understanding and Implementing ISO 9000: 2000*, 2nd ed., Prentice Hall, Upper Saddle River, New Jersey.
- Ho, S.K.M. (1999) *Operations and Quality Management*, International Thomson Business Press, London.
- Ilkay, M.S. and Aslan, E. (2012) 'The effect of the ISO 9001 quality management system on the performance of small and medium enterprise', *Int. J. of Quality and Reliability Management*, Vol. 29, No. 7, pp.753–778.
- International Organization for Standardization (2001) *ISO/TR 10013*, Geneva.
- Pandjaitan, L.E., Syamsun, M. and Kadarisman, D. (2011) 'Study of QMS implementation level on SME's performance in Nata de Coco Agro-Industry Sector in Bogor', *Small and Medium Enterprises Management*, Vol. 6, No. 2, pp.117–124.
- Rawahi, A.M.S. and Bashir, H.A. (2011) 'Investigating the association between organizational differences and the implementation of ISO 9001: 2000', *Proceedings of the 2011 International Conference on Industrial Engineering and Operations Management*, Kuala Lumpur, Malaysia, 22–24 January.
- Sinaga, F.S.M. (1998) *Study of Quality Management System and Food Safety Internship Case in PT Tri Kunci Mas Industri Palembang*, Bogor Institute of Agriculture, Bogor.
- Singh, J. and Singh, H. (2010) 'Assessment of continuous improvement approach in SMEs of Northern India', *Int. J. Productivity and Quality Management*, Vol. 5, No. 3, pp.252–268.
- Sun, H. and Cheng, T-K. (2002) 'Comparing reasons, practices, and effect of ISO 9000 certification and TQM implementation in Norwegian small and medium enterprises (SMEs) and large firms', *International Small Business Journal*, Vol. 20, No. 4, pp.421–442, Sage Publications, London.
- Tague, N.R. (2005) *The Quality Tool Box*, 2nd ed., ASQ Quality Press, Milwaukee.

**Comment [A6]:** Author: Please cite the reference in the text or delete from the list if not required.

**Comment [A7]:** Author: Please cite the reference in the text or delete from the list if not required.

**Comment [A8]:** Author: Please cite the reference in the text or delete from the list if not required.

**Comment [A9]:** Author: Please provide full reference.

**Comment [A10]:** Author: Please cite the reference in the text or delete from the list if not required.

**Comment [A11]:** Author: Please cite the reference in the text or delete from the list if not required.

**Comment [A12]:** Author: Please cite the reference in the text or delete from the list if not required.

**Comment [A13]:** Author: Please cite the reference in the text or delete from the list if not required.

## **Appendix A**

### *PRP 01.02 – design and development procedure*

#### 1 Objective

This procedure aims to ensure the design and development stage is done consistently and in accordance with the applicable provisions.

#### 2 Scope

This procedure describes the procedures for the design and development of products that includes planning, input, output, review, verification, validation, and control of design and development changes.

#### 3 Reference

3.1 Quality manual.

3.2 ISO 9001:2008 clause 7.3.

#### 4 Definitions

The design and development establish processes that change the requirements set into a certain characteristic to the product specification, or system.

#### 5 Responsibility and authority

5.1 Head of production coordinate the planning design and development process.

5.2 QA/QC staff defines and control the design and development stages.

#### 6 Description of activities

##### 6.1 Design and development planning

6.1.1 Head of production set design and development stages.

6.1.2 QA/QC staff set a review, verification, validation, which are appropriate to each stage.

6.1.3 Director assigns responsibility and authority for each stage of design and development.

6.1.4 QA/QC staff coordinates with the production department in the implementation of the product design and development.

6.1.5 If there is a change in plan design and development, design outputs updated during design and development took place.

6.1.6 QA/QC staff record the design and development planning in the form of PRF 01.02.01, design planning and development.

- 6.2 Design and development inputs
  - 6.2.1 QA/QC staff set the input of the design and development of hydrotiller product, which includes:
    - 6.2.1.1 Terms of functionality and performance products.
    - 6.2.1.2 The legislation and regulations applicable.
    - 6.2.1.3 Information derived from previous similar designs.
    - 6.2.1.4 Other essential requirements for design and development.
  - 6.2.2 Source of input to the design and development can be derived from the following things:
    - 6.2.2.1 Market changes, business direction, and the condition of the company.
    - 6.2.2.2 Communication with customers.
    - 6.2.2.3 The direction of top management (board of directors).
    - 6.2.2.4 Experience of the personnel who involved in the production.
    - 6.2.2.5 Requirements/specifications of product quality.
  - 6.2.3 QA/QC staff reviews the completeness of the requirements of the products design and development.
  - 6.2.4 QA/QC staff maintains the input record of the design and development in the form of design and planning, PRF 01.02.01.
- 6.3 Design and development outputs
  - 6.3.1 QA/QC staff set the input of the design and development of product.
  - 6.3.2 Design outputs must allow for verification.
  - 6.3.3 Design and development outputs recorded in the form of design and development, PRF 01.02.01.
  - 6.3.4 Outputs that have been recorded in the PRF 01.02.01 submitted to top management for approval.
  - 6.3.5 QA/QC staff to ensure that design and development outputs able to:
    - 6.3.5.1 Meet the requirements of the design and development input.
    - 6.3.5.2 Provide information for purchasing, production, and after sales service.
    - 6.3.5.3 Refer to the product acceptance criteria (as per specification).
    - 6.3.5.4 Meet the security and convenience products for users.
- 6.4 Design and development review
  - 6.4.1 QA/QC staff of a review of the design and development which include:
    - 6.4.1.1 Capability assessment results to meet the requirements.
    - 6.4.1.2 Identification of the problem and recommended action required.
  - 6.4.2 QA/QC staff maintains a record of the results of the review and actions required on PRF 01.02.02, evaluation and validation of design and development.

- 6.5 Design and development verification
  - 6.5.1 QA/QC staff verifies the suitability of the design and development outputs with the design and development input requirements.
  - 6.5.2 QA/QC staff records the results of the verification and measures in the form of evaluation and verification of design and development, PRF 01.02.03.
- 6.6 Design and development validation
  - 6.6.1 Staff QA/QC validates and conducts the product design and development.
  - 6.6.2 Validation should be completed before the submission or implementation of the production process.
  - 6.6.3 Staff QA/QC record results in PRF 01.02.03 validation and submit the form to the MR and top management.
  - 6.6.4 If top management approved the design and development deserves to be produced, then the relevant sections immediately prepare production plans.
  - 6.6.5 Staff QA/QC maintains records of validation results and actions required during design and development.
- 6.7. Control of design and development changes
  - 6.7.1 Staff QA/QC control and communicate any changes to the relevant section.
  - 6.7.2 Each design and development is reviewed, verified, validated, and approved by top management before implementation.
  - 6.7.3 Review of design and development changes include evaluation of the effect of changes in the products and the products that have been submitted.
  - 6.7.4 Staff QA/QC maintains results of the review of changes and the necessary actions contained in PRF 01.02.03.
- 7 Records
  - PRF 01.02.01 form hydrotiller design and development planning.
  - PRF 01.02.02 form hydrotiller design and development stages.
  - PRF 01.02.03 form evaluation and validation design and development.

Figure A1 Flowchart design and development

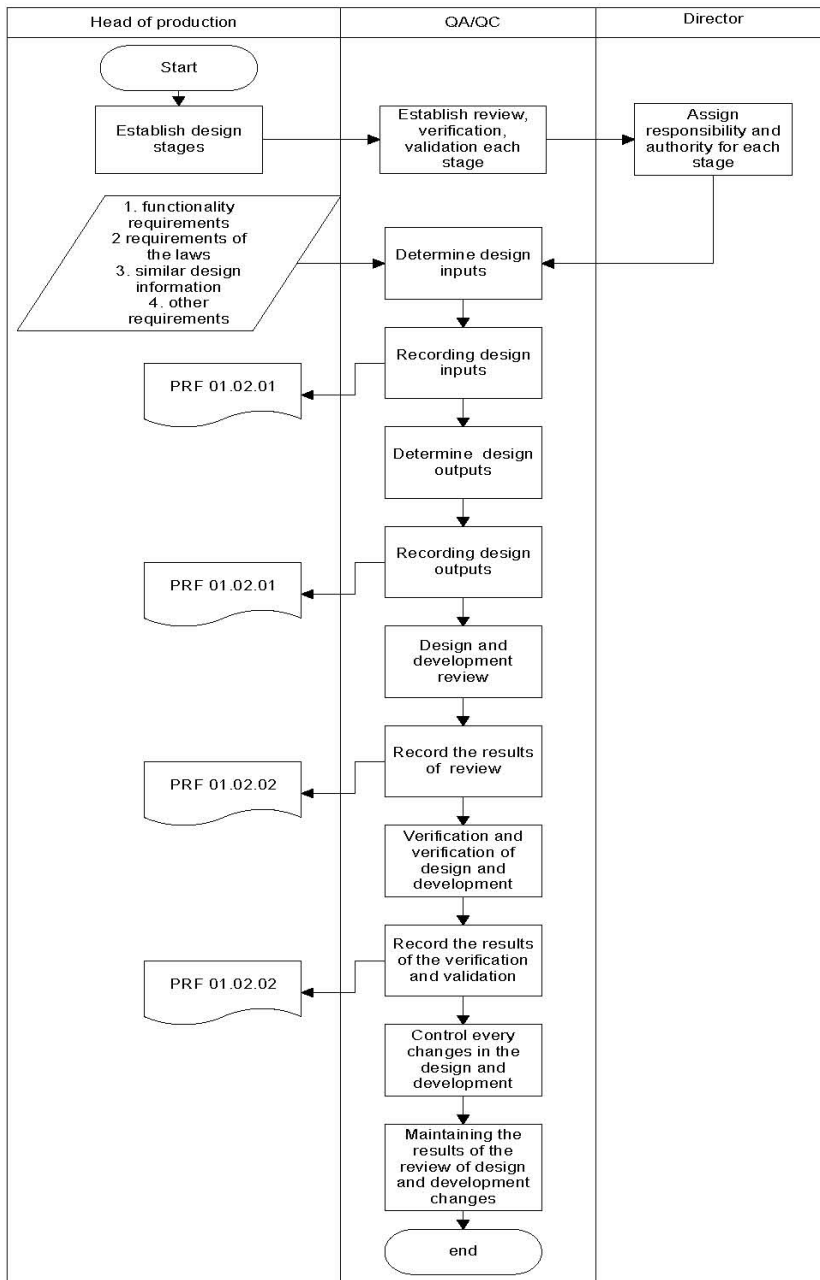

## **Appendix B**

### *WIRP 02.03 – manufacture of hydrotiller*

#### 1 Objective

The aim of WIs is to ensure the process of making hydrotiller run in accordance with the steps set includes the preparation and treatment of raw materials, the first assembly, assembly II, III assembly and painting

#### 2 Scope

It is applied to the process of making hydrotiller in CV Citra Dragon.

#### 3 Reference

- 3.1 Quality Manual.
- 3.2 ISO 9001:2008 clause 7.3.

#### 4 Definition

-

#### 5 Responsibility

- 5.1 The head of the production department is responsible for the process of making hydrotiller.
- 5.2 The production operator is responsible for operating the production, manufacture hydrotiller accordance with WIs.

#### 6 Instruction

##### 6.1 Preparation of the body

- 6.1.1 Measure 2 mm thick plate by using a tape measure or a mall to make the floor.
- 6.1.2 Mark the measurement results with chalk.
- 6.1.3 Cut the plate which has been measured by using a plate cutting machines.
- 6.1.4 Measure 2 mm thick plate by using a tape measure or a mall to make the body amplifier.
- 6.1.5 Cut the plate which has been measured by using a plate cutting machines.
- 6.1.6 Joint the floor and the amplifier into the body by using welding machine as shown in the following figures.

**Figure A2** (a) Body top view (b) Body front view (c) Body side view (d) Body

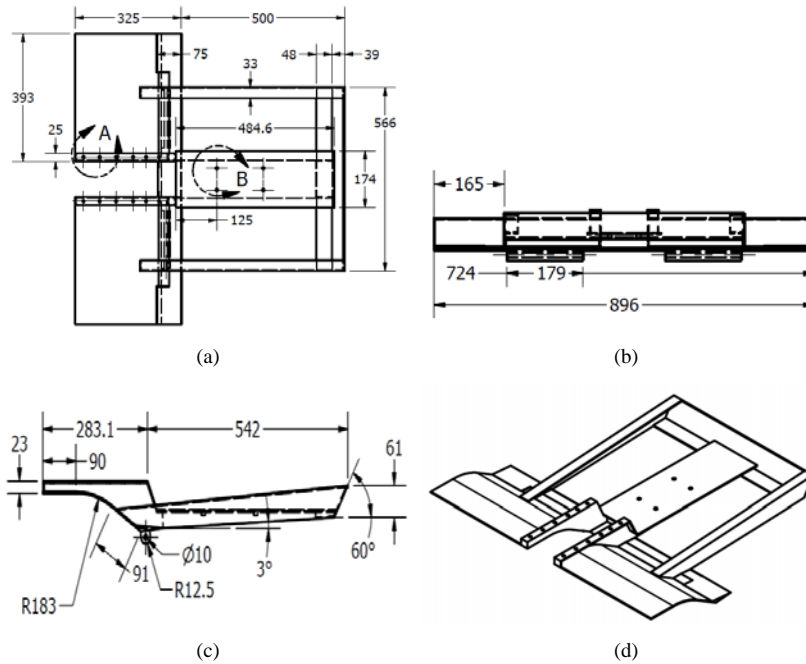

## 6.2 Preparation of pontoon

- 6.2.1 Measure 3 mm thick plate with a tape measure to make pontoon floor.
- 6.2.2 Mark the plate which has been measured by using chalk.
- 6.2.3 Cut the marked plate, then formed by using a press machine to make the floor of the pontoon.
- 6.2.4 Measure 2 mm thick plate with a tape measure to make a pontoon wall.
- 6.2.5 Mark the plate which has been measured by using chalk.
- 6.2.6 Cut the marked plate, then formed by using a press machine to form the walls of the pontoon.
- 6.2.7 Assembly the floor pontoon and walls by welding process.

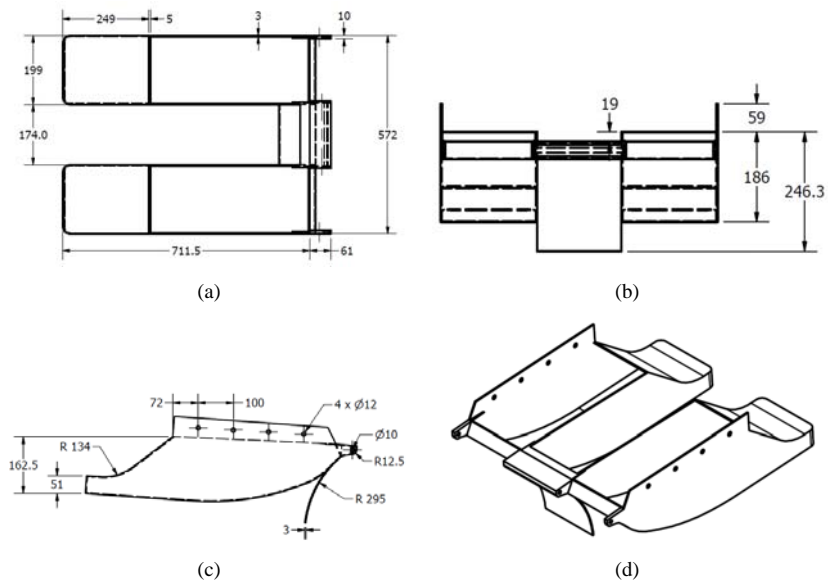
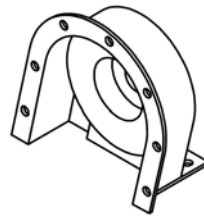
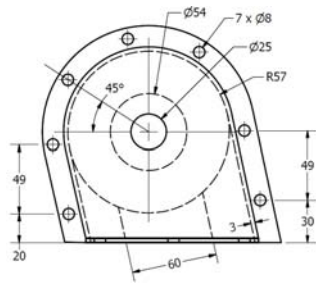

**Figure A3** (a) Pontoon top view (b) Pontoon front view (c) Pontoon side view (d) Pontoon

### 6.3 Preparation of gearbox

- 6.3.1 Measure 3 mm thick plate with a tape measure and mark cutting results.
- 6.3.2 Cut the plate which has been marked by using plate cutting machines.
- 6.3.3 Mark the plate that has been cut to create gearbox housing.
- 6.3.4 Press the plate that has been marked using a press machine.
- 6.3.5 Drill the edge of the gearbox housing to make holes.
- 6.3.6 Measure the iron as with tape measure, then mark.
- 6.3.7 Do the lathing process to the iron as which has been measured to make the axis.
- 6.3.8 Assembly the gearbox housing, axis, large gears, small gears, and chains into the gearbox.

**Figure A4** (a) Upper gearbox housing (b) lower gearbox housing (c) Gearbox axis (d) Transmission system



(a)

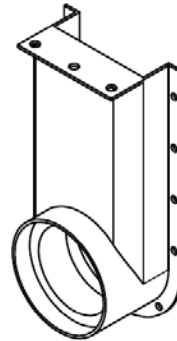
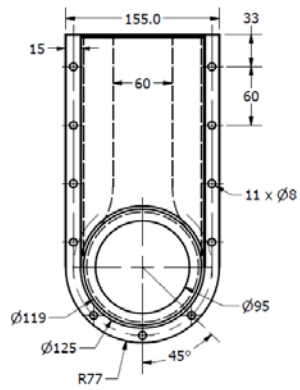

(b)

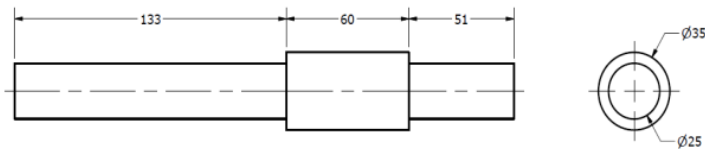
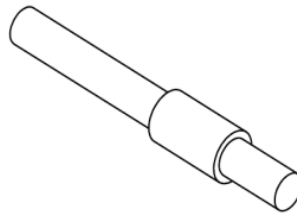

(c)

**Figure A4** (a) Upper gearbox housing (b) lower gearbox housing (c) Gearbox axis  
(d) Transmission system (continued)

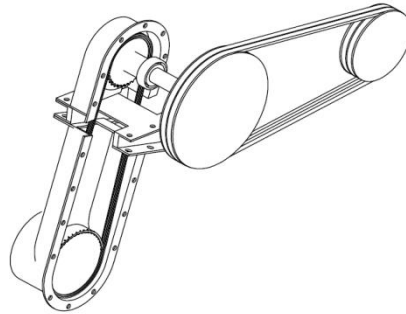

(d)

#### 6.4 Preparation of handle

6.4.1. Measure 2 mm diameter iron pipe with a length of 3,000 mm.

6.4.2 Cut iron pipe which has been measured using a chainsaw or cutting grinding machine.

6.4.3 Bend iron pipe that has been cut to form the letter U and bends down.

6.4.4 Attach the stand around bends down using an iron pipe with a welding process.

6.4.5 Punch a hole through the ends of the iron pipe to be assembled with the body.

**Figure A5** (a) Handle top view (b) Handle (c) Handle side view

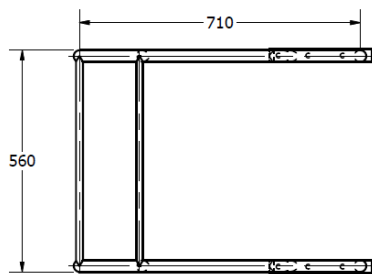

(a)

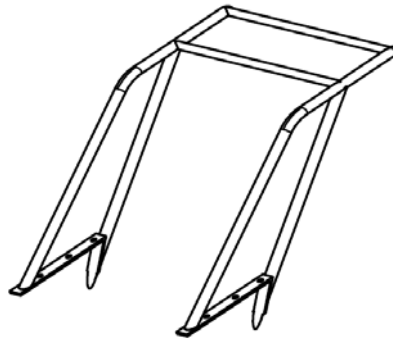

(b)

**Figure A5** (a) Handle top view (b) Handle (c) Handle side view (continued)

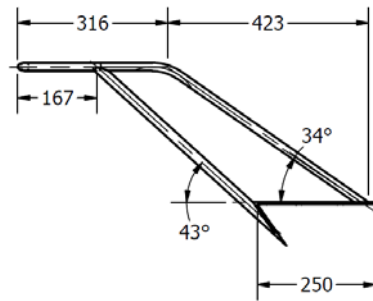

(b)

### 6.5 Preparation of wheels

- 6.5.1 Measure the iron rods of 12 mm diameter with a length of 1,200 mm.
- 6.5.2 Form of iron rods into a circle with a radius of 152 mm and weld the ends. Create as many as 8 circles.
- 6.5.3 Measure and cut iron strip along the spokes of a wheel as many as 32 pieces.
- 6.5.4 Pressed 3 mm thick iron plate to create leaf wheel.
- 6.5.5 Put the pieces to form a wheel by welding process as shown below.

**Figure A6** (a) Wheel Side View (b) Wheel (c) Wheel Front view

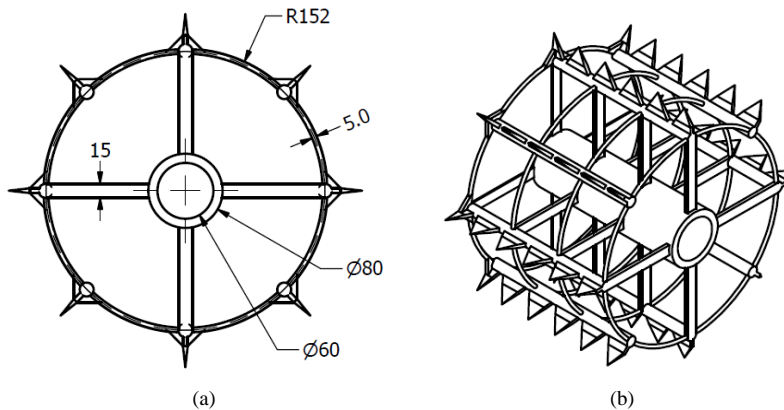

(a)

(b)

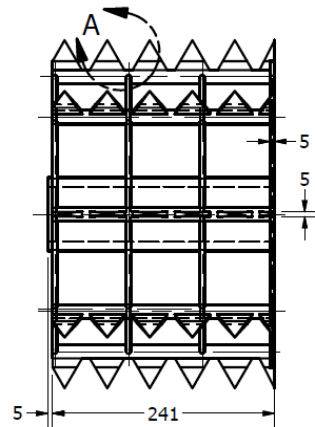
**Figure A6** (a) Wheel Side View (b) Wheel (c) Wheel Front view (continued)

(c)

- 6.6 Assembly I (body, pontoon, and gearbox)
  - 6.6.1 Assemble components of the body using a welding machine.
  - 6.6.2 Trim and clean the floor assembly with a grinding process using a grinding machine.
  - 6.6.3 Assemble components of pontoon using a welding machine.
  - 6.6.4 Assemble components of gearbox using a welding machine.
  - 6.6.5 Assemble body to pontoon by using a welding machine, nuts, and bolts.
  - 6.6.6 Assemble body and pontoon with gearbox using welding machines, nuts, and bolts into assemblies I.
  - 6.6.7 Trim and clean the assembly I with the grinding process by using a grinding machine.
- 6.7 Assembly II (assembly I and handle)
  - 6.7.1 Assemble the entire components of the handle using a welding machine, nuts, and bolts.
  - 6.7.2 Assemble assembly I and handle into assembly II using welding machines, nuts, bolts, and washers.
  - 6.7.3 Trim and clean the assemblies II with grinding process using a grinding machine.
- 6.8 Assembly III (finished product)
  - 6.8.1 Assemble the entire components of the wheel using welding machine, nuts, and bolts.
  - 6.8.2 Assemble assembly II and wheel using welding machines, nuts, bolts, and washers.

- 6.8.3 Assemble assembly II and the pulley wheel, pulley cap, and retaining iron pulley into assembled III/finished products.
- 6.8.4 Trim and clean the finished product with the sanding process.
- 6.8.5 Ensure/check assembly II has met the requirements set.
- 6.8.6 Paint finished product using priming and dry.
- 6.8.7 Paint finished products neatly with paint as needed and dry.
- 6.8.8 Store the finished product in the warehouse.

**Figure A7** Hydrotiller

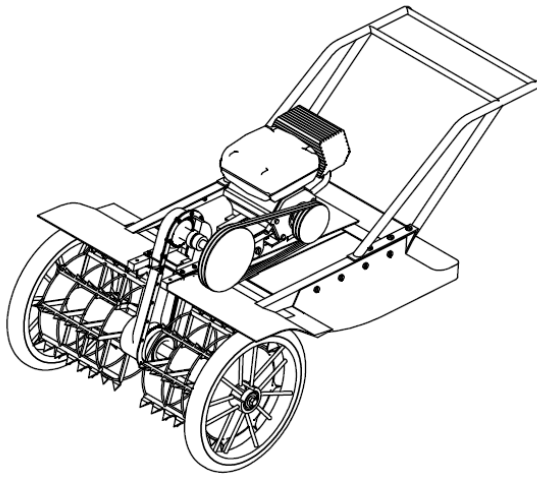

**Appendix C**

*PRF 01.02.02 form hydrotiller design and development stages*

*Design and development stages*

---

<i>No.</i>	<i>Design and development stages</i>	<i>PIC</i>	<i>Work schedule</i>		<i>Description</i>
			<i>Start</i>	<i>End</i>	

---

---

.....  
Made by,  
Head of Production

.....  
Approved by,  
Director