

EXPERIENTIAL MARKETING, CUSTOMER SATISFACTION and BEHAVIORAL INTENTION at TIMEZONE GAME CENTER SURABAYA

Christina Rahardja Honantha

Email: christina_r@ubaya.ac.id or crhonantha@gmail.com

Lecturer of Management Department Faculty of Business and Economics UBAYA

Dudi Anandya (Doctor Candidate)

Email: samkidud@gmail.com

Lecturer of Management Department Faculty of Business and Economics UBAYA

Abstract

The Experience Economy now affect the progression of economics and customer value will increases whether companies offer memorable experiences, then Experiential Marketing focuses on customer experiences from sense, feel, think, act and relate, then concludes customers as affective decision makers.

There is a lack of research on emotional response of service companies, and this research is directed to fill in the gap. Research aims to analyze the effect of experiential marketing on customer satisfaction, the effect of experiential marketing on behavioral intention, and the effect of customer satisfaction on behavioral intention at Time zone game center Surabaya. Data is analyzed by structural equation modeling (SEM) with AMOS 4.0.

The results show that hypothesis one is accepted, experiential marketing affects customer satisfaction at Time zone, hypothesis two is also accepted, experiential marketing affects behavioral intention of Time zone's customer, but hypothesis three is rejected, customer satisfaction do not affect behavioral intention at Time zone game center Surabaya.

Keywords: Experiential Marketing, Customer Satisfaction, Behavioral Intention

Introduction

Today few customers rely on more choice the product as a product's character or usefull benefit. We face the age of The Experience Economy which is the main issues is to get the total experience, unique value system, and way of life. There is a need to understand life of customer in the look of 'experience', practically approach customers' need. The definition of experience in this study is "The apprehension of an object, thought, or emotion through the senses or mind or active participation in events or activities, leading to the accumulation of knowledge or skill (YOON Sekyun, KIM Taekyun, CHAE Sungzin, 2002).

Experiential Marketing as the new way of considering marketing concentrates more on the induction of experiments, that at the end will result in purchase behavior. It treats consumption like a total experiment, takes into account at the same time the rational and emotional springs of consumption and uses eclectic methods. The man of marketing must seek to stimulate five fields of experiments: sense, feel, think, act and relate. Experience is usually motivated by extrinsic stimuli, thus marketers should provide experiential stimuli to customers. Experiences are inherent in the minds of everybody, and the results of involving in physical, emotional, and cognitive activities. Experiences come from the interaction of personal minds and events, and thus no one experiences the same with the other person (Schmitt, 1999).

Timezone game centers are known as a places for children, young adults and families to experience the enjoyable games such as kiddy ride, game with shotgun: time crisis, motor riding, maximum tune car rising, etc. Timezone had already awarded an "Experiential Marketing Award 2005" (<http://www.timezone.co.id> and <http://www.exmarketing.com>).

This paper aims to analyze the affect of experiential marketing on customer satisfaction, the affect of experiential marketing on behavioral intention, and the affect of customer satisfaction on behavioral intention at Timezone game center Surabaya.

Conceptual Foundation

Olorunniwo, F., Hsu, M.K., Udo, G.J. (2006) explored the relationship between service quality, customer satisfaction and behavioral intention at Hotel, it showed that the relationship between service quality and behavioral intention was direct but also indirect. The differences between Olorunniwo, et al. (2006) research and this research are about the analysis of customer satisfaction from affect factor, and the object of research. Moreover, Liljander and Strandvik (1996) explained that customer emotion affect on satisfaction, but have not investigated empirically. Price, L.L., Arnould, E.J., and Deibler, S.L. (1995) studied about consumer's emotion, then said there is a research gap of emotional response at services.

According to Liljander and Strandvik (1996), research on service quality and satisfaction is an cognitive construct rather than affective construct. Furthermore, Yie-Fang Kao, Li-Shia Huang, Ming-Hsien Yang. (2007) had suggested that experiential marketing as same as customer experiences and customer as affective decision makers for enjoyment, excitement and fun consumption, like Timezone game center.

Affect is a general word for several related but different concepts and normally represents mood, emotion, and feelings (Russell, 2003). Affect is conceived as an umbrella for a set of more specific mental processes including emotions, moods and attitudes (Bagozzi, R.P., Gopinath, M., and Nyer, P.U., 1999; Liljander and Mattsson, 2002). The most important factors in experiential consumption are emotional factors, which are personal perception of emotions (Russell and Snodgrass, 1987). Affective reaction toward interacting with an object is a person's subjective perception or judgment about whether such interaction will change his or her core affect or his or her emotion toward the object. Cognitive reaction toward interacting with the object involves cognitive reasoning or appraisal, and is a weighting of the implications of an event for one's well being. Cognitive reaction and affective reaction toward interacting with an object can be quite different, for example: one might appraise taking a medicine as useful and necessary for one's health, nevertheless, one can at the same time consider it unpleasant due to the smells and tastes of the medicine. Schmitt (1999) explained experiential marketing is how to get customers to sense, feel, think, act, and relate to your company and brands.

Satisfaction is defined as the "customer fulfillment response" which is an evaluation as well as an emotion based response to a service. It is an indication of the customer's belief on the probability of a service leading to a positive feeling. Positive affect was positively and negative affect negatively related to satisfaction (Liljander and Strandvik, 1997). Hanan and Karp (1995) evaluate dimension of customer satisfaction that are called "the big eight", and divide into three factors: product-related factors, service-related factors, and purchase factors. Therefore, *the hypothesis one is: experiential marketing affects on customer satisfaction at Timezone Surabaya.*

According to a model present by ZBP (1996), behavioral intentions can be captured by such measures as repurchase intentions, word of mouth, loyalty, complaining behavior, and price sensitivity. Olorunniwo et al. (2006), concluded that customer experience is related to behavioral intentions. *Hypothesis two is: experiential marketing affects on behavioral intention at Timezone Surabaya.*

Satisfied customers who stay with a company for a long period tend to impact the probability of the company in several ways. First, their repeat business generates income for the company. Second, because of the expenditure involved in advertising, promotion, and start-up activities, acquiring new customers can cost much more than retaining existing ones. Third, loyal (and satisfied) customers often "spread the good news" and recommend the services to several others (Olorunniwo et al., 2006). Customer satisfaction affect on repurchase intentions or behavioral intention (Cronin, J. Joseph, Michael K. Brady, G.Thomas M. Hult., 2000), therefore *hypothesis three is: customer satisfaction affects on behavioral intention at Timezone Surabaya.*

Research Methodology and Data

Experiential marketing dimensions are "sense" (includes the types of games, the sound of games), "feel" (includes the excitement and fun), "think" (includes skill experience, score achievement), "act" (includes playing games), and "relate" (includes relationship among gamers, communication with others). Customer satisfaction dimensions are "related to the products" (includes value to price relationship, games quality, games features), "related to the service" (includes warranty and response to remedy problem), and "related to purchase" (includes sales experience and convenience of acquisition). Behavioral intention dimensions are "recommend Timezone to others", "say positive thing of Timezone", "remain loyal to Timezone", "pay price premiums", and "spend more". Each item was rated on a seven-point Likert-type scale ranging from strongly disagree to strongly agree.

Primary data are collected from respondents with 13 through 30 years old and ever play games more than once a month. Questionnaires were distributed to 225 respondents at Timezone Surabaya and were generated a valid data for 105 respondents.

Data Analysis

A structural equation or the structural equation modeling (SEM) is proposed. The model that proposed in this paper investigates the affect of experiential marketing on customer satisfaction, the affect of experiential marketing on behavioral intention, and the affect of customer satisfaction on behavioral intention at Timezone game center Surabaya. SEMs are made up of two components: first, describes the relationship between endogenous and exogenous latent variables and permits the evaluation of both direction and strength of the causal affects among latent variables, second, describe the relationship between latent and observed variables. SEM is a technique to test a structural theory (Hair, Black, Babin, Anderson, Tatham, 2006). SEM is generally estimated by using the maximum likelihood method. Figure 1 is the structural equation modeling of experiential marketing, customer satisfaction and behavioral intention at Timezone Surabaya.

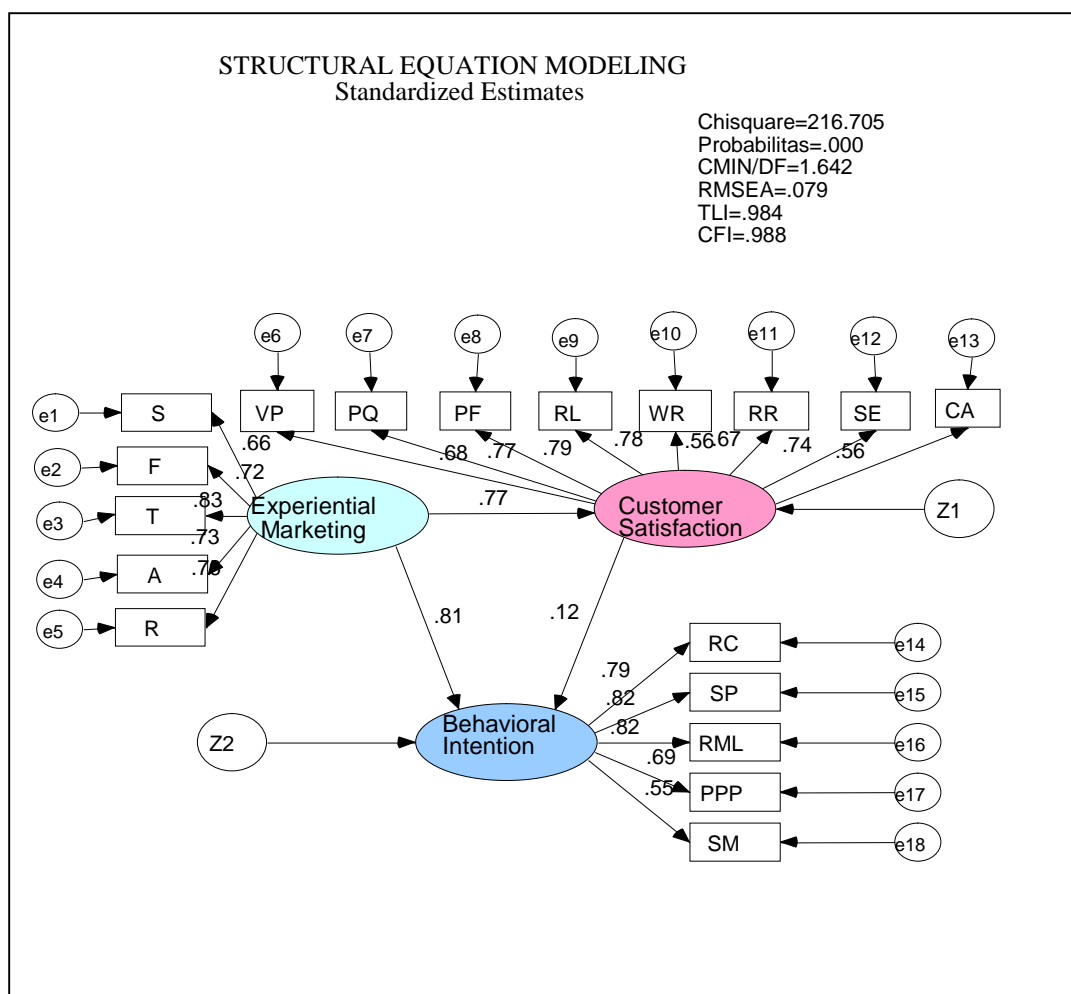

Figure 1.

Structural Equation Modeling

Structural Equation Modeling (SEM) methodology spread fast as a consequence of the development of specific packages, like AMOS version 4.0 (Augusty, F. 2005). SEM is used to analyse the conceptualised, comprehensive model of experiential marketing, customer satisfaction, and behavioral intention. Examination of the model through path analysis indicated that the hypothesised model is a good fit to the data to a reasonable extent. The model had Chi-square of 216.705. the relative Chi-square is considered high by some researchers who contended that values in excess of 2.0 will represent an inadequate model fit. However, other researchers suggested that ratio 5 or less

indicates reasonable model fit. The use of Chi-square test may not be a strong test for goodness-of-fit as it is very sensitive to sample size (Armstrong, Robert W. And Tan Boon Seng, 2000). In an effort to achieve strong validity and reliability, CFA was employed. The fit indices in Figure 1 presented the standardized factor loadings. All dimensions of experiential marketing have a significant and positive relationship on customer satisfaction (0.77). Then, all dimensions of experiential marketing have a significant and positive relationship with behavioral intention (0.81). On the other hand, a statistically significant but relatively smaller standardized regression coefficient (0.12) is observed between customer service and behavioral intention. Fit indices included a comparative fit index (CFI) ≥ 0.95 , and the root mean square error of approximation (RMSEA) ≤ 0.08 .

Conclusions and managerial implications

The 18-item instrument was analyzed using SEM, and the findings indicate that experiential marketing is an important driver or affects on customer satisfaction and behavioral intention. In order to successfully operate game center like Timezone that gives customer a memorable, excitement experience, and Timezone managers need to understand what customers want and the frequency of customers repurchase intentions.

Future research should improve the samples of respondents and investigate the affect of customer satisfaction on behavioral intention at different frequency of playing games.

References

- Augusty, Ferdinand. (2005), *Structural Equation Modeling dalam Penelitian Manajemen*, edisi 3, BP. UNDIP.
- Armstrong, R.W. and Tan Boon Seng. (2000), "Corporate-customer Satisfaction in the banking industry of Singapore", *International Journal of Bank Marketing*, 18/3, 97 – 111.
- Cronin, J. Joseph, Michael K. Brady, G.Thomas M. Hult. (2000), "Assesing the Affects of Quality, Value, and Customer Satisfaction on Consumer Behavioral Intentions in Service Environments." <http://www.msu.edu/~hult/publications/JR00.pdf>.
- Hair, Joseph F. Jr, William C. Black, Barry J. Babin, Rolph E. Anderson and Ronald L. Tatham. (2006), *Multivariate Data Analysis*, Pearson, Prentice Hall.
- Hanan, M., dan Karp, P. (1991), *Customer Satisfaction: How to Maximize, Measure, and Market Your Company's Ultimate Product*, New York: AMA.
- Liljander, Veronica dan Tore Strandvik. (1997), "Emotions in Service Satisfaction," *International Journal of Service Industry Management*, 8 (2), 148-169
- Olorunniwo, Festus, Maxwell, K. Hsu dan Godwin J. Udo. (2006), "Service Quality, Customer Satisfaction, and Behavioral Intentions in the Service Factory," *Journal of Service Marketing*, 20 (10), 59-72.
- Price, L.L., Arnould, E.J., and Deibler, S.L. (1995), "Consumers' emotional responses to service encounters", *International Journal of Service Industry Management*, Vol. 6 No.3. pp 34 – 63.
- Russell, J.A. (2003), "Core Affect and the Psychological Construction of Emotion." *Psychological Review*, 110 (1), 145-172.
- Schmitt, Bernd, H. (1999), *Experiential Marketing: How to Get Customers to Sense, Feel, Think, Act, Relate to Your Company and Brands*. New York: The Free Press.
- Sekyun Yoon, Kim Taekyun, Chae Sungzin. (2002), "A Study of Experience Design Application Model under Tangible off-line Product Environment," *Education phylosophy, a Institute of Korea Philosophy Education*, 16, 240-249.
- Yie-Fang Kao, Li-Shia Huang, Ming-Hsien Yang. (2007), "Affects of Experiential Elements on Experientials Satisfaction and Loyalty Intentions: A Case Study of the Super Basketball League in Taiwan," *International Journal Revenue Management*, Vol. 1 (1), 79-96.
- Zeithaml, V.A., Berry, L.L., and Parasuraman, A. (1996), "The Behavioral Consequences of Service Quality," *Journal of Marketing*. Vol. 60, 31-46.

<http://www.timezone.co.id>

<http://www.exmarketing.com>