

PAPER • OPEN ACCESS

Geoelectrical Investigation the Depth of Groundwater Potential for Irrigation of Paddy Fields

To cite this article: N R Yanti *et al* 2020 *IOP Conf. Ser.: Earth Environ. Sci.* **515** 012044

View the [article online](#) for updates and enhancements.

You may also like

- [Effects of Different Depth of Discharge on Cycle Life of LiFePO₄ Battery](#)
Jin Tang, Jianling Li, Feixiang Ding et al.
- [Depth estimation of the aquifer layer using the geoelectric resistivity method](#)
F D Sastrawan, Asrafil and E G Prasetya
- [Identification of seawater intrusion using geoelectrical resistivity method in the Goa Cina Beach Malang Area, Indonesia](#)
M F R Hasan, C D Fransiska, D A Suaidi et al.

Geoelectrical Investigation the Depth of Groundwater Potential for Irrigation of Paddy Fields

N R Yanti¹, F Arlius¹, Rusnam¹, I Berd¹, E G Ekaputra¹, S A Setyoningrum¹

¹Department of Agricultural Engineering, Andalas University, Padang, Indonesia

Corresponding author's e-mail address: nikary@ae.unand.ac.id

Abstract. Groundwater is an opportunity for the irrigation of Paddy fields. A paddy field that is planted only one crop during the rainy season is an obstacle to the lack of rice production in the city of Padang. Meeting the need for rice consumption was sent from various western Sumatra areas. If this happens, again and again, it would threaten food security. This research to determine the depth of groundwater table potential has been carried out in Koto Tangah, Padang city. This study using the geoelectric resistivity method with Schlumberger Configuration and data processing using software IP2WIN. The resistivities value of these zones varies from 1.8 Ω m to 1761 Ω m. Layers found to the depth 20 m are a sub-surface layer, clay, sandy clay, and gravel. Layers of clay identified as Groundwater because it's small so it can withstand water. Based on the results of comparative research data measurement of the estimation of the depth of the ground water level with a geoelectric tool and the depth of the ground water with a piezometer device obtained close relationship. So, from these results a linear regression equation can be made with the form of the equation $\hat{Y} = 0.793X + 0.838X + 0.3636$ and has an R^2 of 0.8765.

Keywords: Geoelectrical, Groundwater table, Irrigation, Resistivity

1. Introduction

Water is one of the most important components of agriculture. To date, the surface water source is a mainstay for irrigation water in agricultural use. But not all of the land that has farmland that has surface water. Some parts of Indonesia still rely on rainwater from irrigating of paddy field. According to the potential for land, these rainfed paddy fields are promising the future to develop. The salient issue of the rainfed paddy fields is low productivity, a major cause of drought is the unpredictable supply of rainwater, in addition, land fertility and pH low.

To irrigate paddy fields, farmers only rely on rainwater in the wet month. The alternative to meet water needs is to make irrigation, but this requires a very large cost. so that the activity can only be operated with government assistance. A workable alternative to using groundwater.

Before groundwater becomes an irrigation water source it should first be evaluated at the potential for groundwater in the area. Water exposure is greatly influenced by some factors: morphology, geology, rainfall and land use. To determine the potential and characteristics of groundwater in an area can be determined by the geoelectrical investigation method [6]

The purpose of electrical surveys is to determine the subsurface resistivity distribution by making measurements on the ground surface [4]. The electrical resistivity technique enables the determination of subsurface resistivity by sending an electric current into the ground and measuring the potential



field generated by the current. The depth of penetration is proportional to the Schlumberger array which uses closely spaced potential electrodes and widely spaced current electrodes [5]

2. Methods

This research was conducted in the Koto Tengah District of Padang City. Data is collected at 10 points of investigation (Figure 1). Geographically, it is located at $0^{\circ} 58'$ South Latitude and $100^{\circ} 21' 11''$ East Longitude, and is at three 0 meters above sea level - 1600 meters above sea level. The area of Koto Tengah District is $\pm 232.25 \text{ Km}^2$ for the population of 168,194.

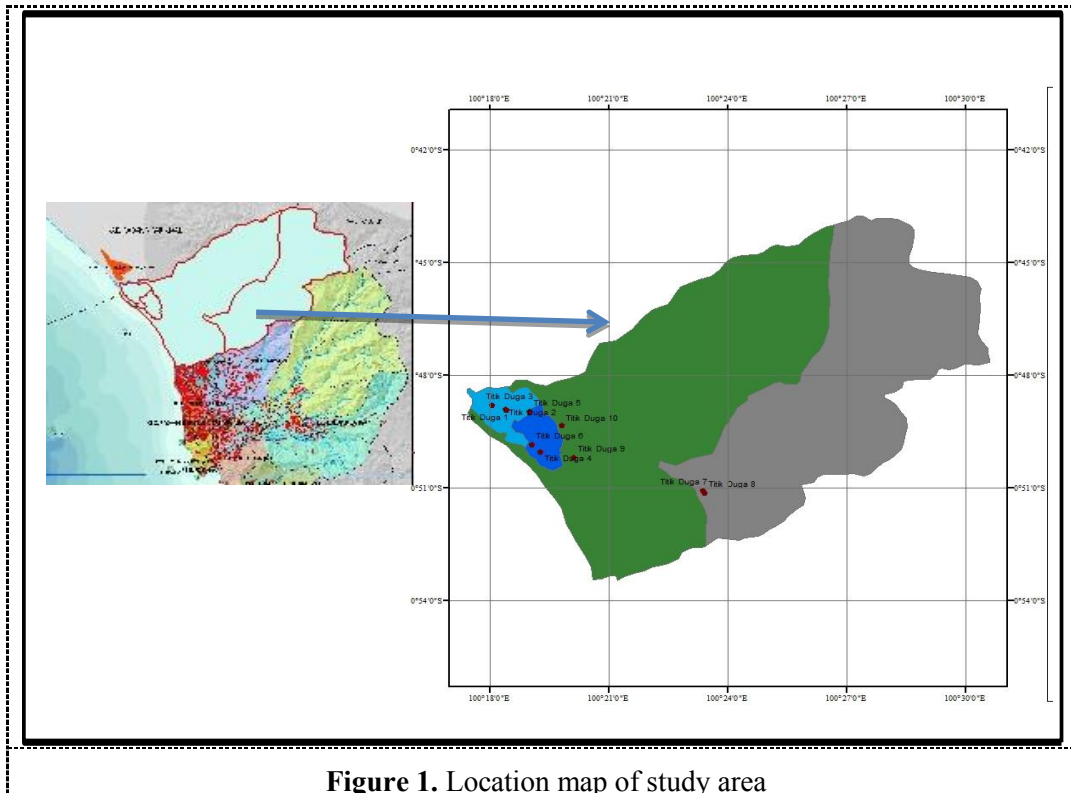

Figure 1. Location map of study area

Table 1. Points of sounding with coordinates

Point	Latitude	Longitude
1	$0^{\circ} 48' 56,165''$	$100^{\circ} 18' 25,534''$
2	$0^{\circ} 48' 55,310''$	$100^{\circ} 18' 23,643''$
3	$0^{\circ} 48' 48,113''$	$100^{\circ} 18' 3,947''$
4	$0^{\circ} 50' 2,853''$	$100^{\circ} 19' 17,047''$
5	$0^{\circ} 48' 58,865''$	$100^{\circ} 19' 0,839''$
6	$0^{\circ} 49' 51,470''$	$100^{\circ} 19' 3,777''$
7	$0^{\circ} 51' 5,341''$	$100^{\circ} 23' 23,087''$
8	$0^{\circ} 51' 8,944''$	$100^{\circ} 23' 25,669''$
9	$0^{\circ} 50' 12,457''$	$100^{\circ} 20' 7,13''$
10	$0^{\circ} 49' 21,143''$	$100^{\circ} 19' 48,654''$

The materials used in this study are maps of the administration of the city of padang.

The tools used in conducting this research are:

1. Geoelectric measuring device.
2. Four electrodes as conductors of electricity are implanted on the ground surface.
3. Power cord.
4. Meter to measure length.

5. GPS navigation for taking coordinate points.
6. IP2WIN software to facilitate work in data processing.

Investigation of ground water level in the Koto Tengah District in this study using the geoelectrical method using Schlumberger configuration. This method in principle is to find out the apparent resistivity value of subsurface material by injecting or passing a certain large direct current into the ground. The depth of the estimation has a positive correlation with the electrode range. The greater the range, the greater the distance the range. As shown in Fig 2 this method uses four electrodes stuck to the ground on a line along the measurement with the position of the potential electrode located between a pair of current electrodes.

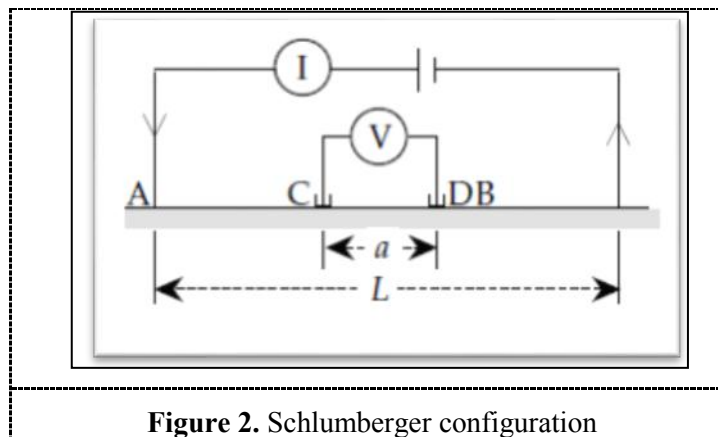

Figure 2. Schlumberger configuration

From the research location 10 investigation points will be determined to measure the potential for ground water level depth. At each guess point the distance electrode measurements were taken along 20 meters, and at each distance range of 1.5 m, 2 m, 2.5 m, 4 m, 5 m, 6 m, 8 m, 10 m, 12 m, 15 m, 20 m. Data obtained from the measurement of simple geoelectric devices are voltage and current strength values. Furthermore, the data is processed to obtain the value of apparent resistivity (apparent resistivity). The resistivity geoelectric method is based on the assumption that the earth has isotropic homogeneous properties. With this assumption, the measured resistivity is the actual resistivity and does not depend on the electrode spacing. But in reality the earth is composed of layers with varying resistivities, so the measured potential is the effect of these layers. Therefore the measured resistivity is as if the resistivity value is only for one layer. So the measured resistivity is apparent resistivity.

2.1. Data processing

Field measurements using a geoelectric will get the value of voltage (V) and current strength (I) and to get the apparent resistivity (resistivity) [1], the apparent value of prisoners can be calculated with

$$\rho\alpha = C \frac{V}{I} \quad (1)$$

Where, $\rho\alpha$ is apparent resistivity (Ωm), V is voltage (mV), I is current (mA), and C is Schlumberger Constant.

The resistivity value is inputted into the IP2WIN software to determine the groundwater depth estimation. From the results of processing with IP2WIN, the resistivity value (ρ), depth (h), and thickness of each underground rock layer will be obtained (d).

2.2. Groundwater level testing with a piezometer

The measurement results obtained by using a geoelectric instrument will be tested back to the location by measuring the depth of the ground water level using a piezometer to compare the measurement results of the geoelectric tool in estimating the depth of the ground water level. Measurements with a piezometer are carried out at each location of the guess point. This is done in order to obtain data at

each location of the estimated point in estimating the depth of the ground water level using geoelectric devices and piezometers

2.3. Data analysis

The figures obtained in the software are for resistivity, layer depth, and rock layer thickness. Data obtained from geoelectric measurements with measurements using a piezometer will be compared. So, from the comparison of these data can produce information on geoelectric tools to estimate the depth of the ground water level in the form of a linear regression equation.

The regression equation model used is:

$$Y = a + bX \tag{2}$$

Where Y is Depth of actual ground water level, X is Depth of ground water level from geoelectric devices, a is interception, and b is The direction coefficient of the regression line showing the magnitude of the change in Y when there is a change in X

3. Results and Discussion

3.1. Geoelectrical Sounding

Interpretation is done by looking at the geological state and determining the type of rock in each layer. Based on the differences in the results of resistivity (resistivity) data, it can be seen the lithology or rock type of each layer of each geoelectric point.

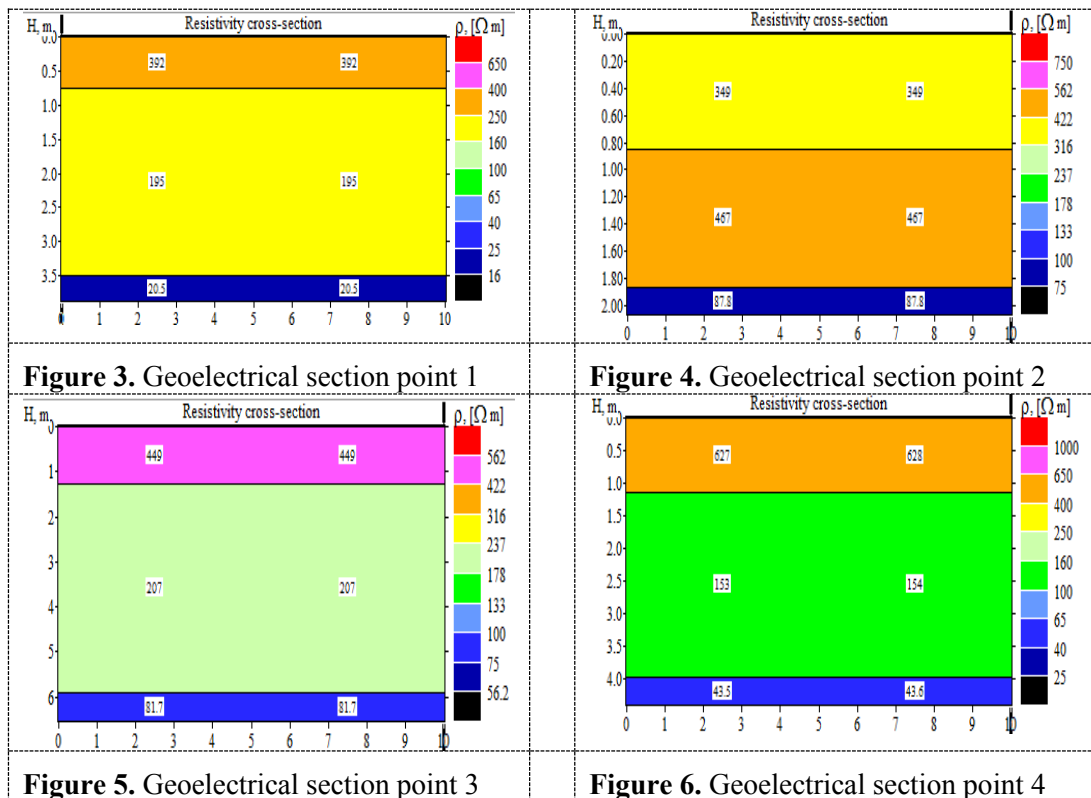

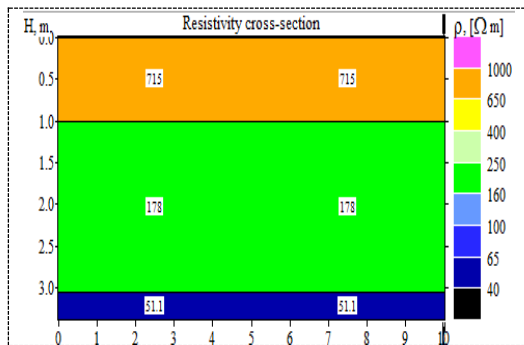

Figure 7. Geoelectrical section point 5

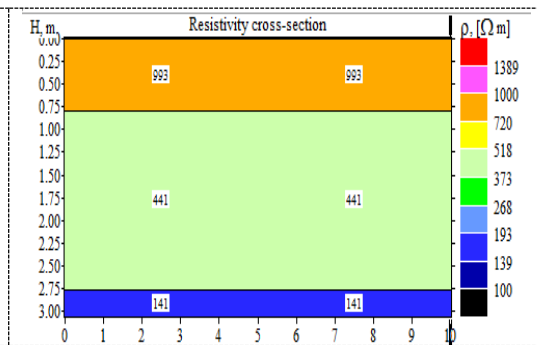

Figure 8. Geoelectrical section point 6

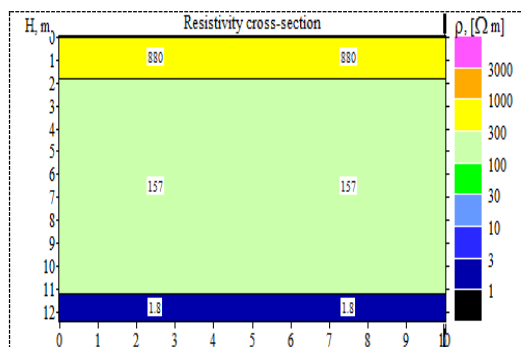

Figure 9. Geoelectrical section point 7

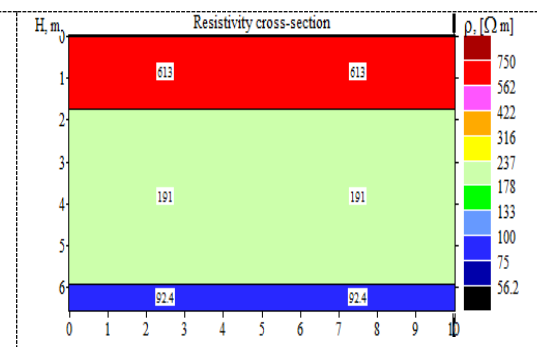

Figure 10. Geoelectrical section point 8

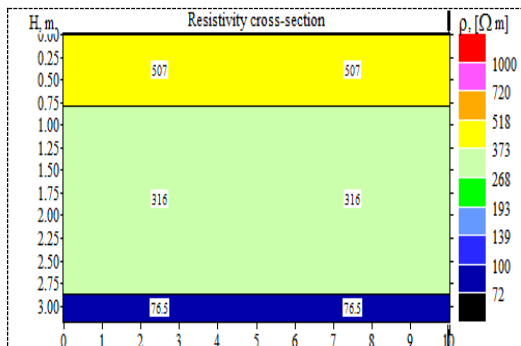

Figure 11. Geoelectrical section point 9

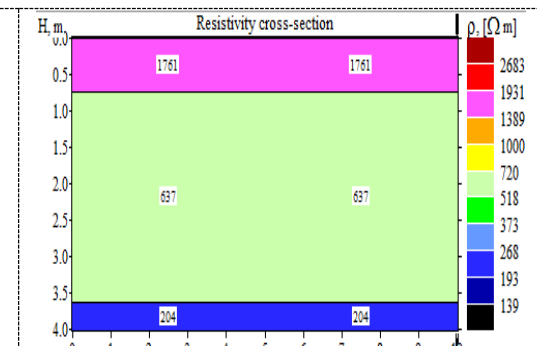

Figure 12. Geoelectrical section point 10

Based on the geological map, the stratigraphic sequence of the study area consists of sedimentary rocks, namely alluvium (Qal). Large sizes of sedimentary rock grains include; gravel 2 mm - 7.6 mm, sand 2 mm, silt 1/16 mm and clay <1/256 mm. Large rock grains will greatly affect the ability of rocks to pass and store water [2].

Based on the resistivity values, four rock layers (lithology) are obtained are :

1. Cover layer, constituting the topmost layer of the study site, so that it is possible as a top soil
2. The sandy clay layer has a density high enough that it cannot escape water but is not suspected to be a water-bearing layer
3. The sandy clay layer, which is thought to be a water-carrying layer and contains water, because it has a small size so that the ability to hold water is high and cannot escape water..
4. The layer of gravel sand cannot be said to be a water-carrying layer because of its relatively large size which causes this layer to escape large water and cannot hold water.

The second layer of data interpretation results at each point indicates that there is a layer of clay sand with a resistivity range of 100 Ωm - 600 Ωm which can be interpreted as a water-carrying layer. Whereas the slit layer of the clay with a resistivity range of 10 Ωm - 200 Ωm is a layer of rock that is wet and contains water, the resistivity value of its type is low and even lower if it contains brackish or salty water (Soenarto, 2003).

3.2. Piezometer

the potential for groundwater depth obtained by using geoelectric and piezometer devices varies. At each point the guess has a different result (Table 2).

Table 2. The depth of Groundwater

Point	Groundwater with Geoelectrical (m)	Groundwater with Piezometer (m)
1	0,75	1,1
2	0,851	1,25
3	1,4	1,45
4	1,14	1,3
5	0,999	1,05
6	0,801	0,95
7	1,83	1,9
8	1,74	1,9
9	0,794	1,2
10	0,75	0,8

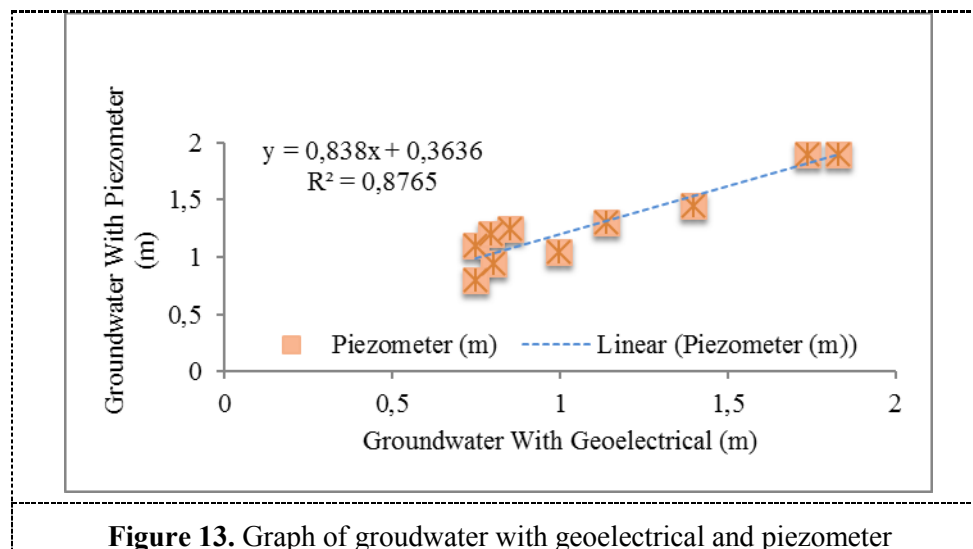

The graph of the relationship between the measurement of the depth of the ground water level with a piezometer and the estimation of the depth of the ground water level with a geoelectrical tool has a value of $R^2 = 0.8765$. This shows that the estimation of the ground water level obtained using a geoelectrical device and the ground water depth obtained using a piezometer have a high relationship. A value of R^2 close to one means that the independent variables provide almost all the information needed to predict the dependent variable.

3.3. Groundwater for Irrigation Paddy Fields

Based on its utilization there are two types of groundwater namely shallow groundwater and deep groundwater [3]. This grouping is very closely related to groundwater utilization and infrastructure needs. Shallow ground water is water found in layers of soil or rocks below the surface of the soil at a

depth of less than 30 m and deep ground water at a depth of 30 m. Groundwater is one of the choices of water sources that can be developed for agriculture. Groundwater potential in a region is relatively fixed. Intake of ground water in accordance with the ability to fill, in addition to increasing agricultural productivity also allows the acceleration of ground water circulation.

4. Conclusion

Koto Tangah District is an area that has potential for shallow ground water that can be used for irrigating rice fields with the help of shallow irrigation pumps. The depth of the ground water level based on geoelectric measurements is at a depth of ≤ 2 m. This is evidenced by the close relationship between the estimation of the ground water level using a geoelectric tool with the actual ground water level using a piezometer. Comparison of the results of the data obtained is connected in a linear regression equation, with the form of the equation $\hat{Y} = 0.838X + 0.3636$, which in this equation has a determination or R^2 of 0.8765.

References

- [1] Damtoro 2007 *Geolistrik Konfigurasi Schlumberger*
- [2] Edwiza D 2010 *Buku Ajar Pengetahuan Geologi Rekayasa* (Padang: Universitas Andalas)
- [3] Kementerian Pertanian 2011 *Pedoman Teknis Pengembangan Irigasi Tanah Dangkal dan Irigasi Tanah Dalam*. (Jakarta: Direktorat Pengelolaan Air Irigasi) 2p
- [4] Loke M H 2000 *Electrical imaging surveys for environmental and engineering studies* (Malaysia: University Sains Malaysia) 1p
- [5] Nejad H T 2009 *Geoelectric Investigation of the Aquifer Characteristics and Groundwater Potential in Behbahan Azad University Farm, Khuzestan Province, Iran* Journal of Applied Sciences **9 (20)** 3691-3698
- [6] Wibowo M 2011 Identifikasi Aquifer Air Tanah di Kec. Taman Sari Tasikmalaya dengan Metode Geolistrik (Bandung: Badan Pengkajian dan Penerapan Teknologi) 2p