

Coordination and Security Assessment of Distribution Feeder with Intermittent Renewable Generation

by Syafii Syafii

Submission date: 26-Feb-2022 07:58AM (UTC+0800)

Submission ID: 1771056721

File name: f_Distribution_Feeder_with_Intermittent_Renewable_Generation.pdf (915.25K)

Word count: 3980

Character count: 18935

Coordination and Security Assessment of Distribution Feeder with Intermittent Renewable Generation

4 Syafii

Electrical Engineering Department,
Engineering Faculty, Universitas
Andalas
Padang, Indonesia
syafii@eng.unand.ac.id

Athalia Alfac

Electrical Engineering Department,
Engineering Faculty, Universitas
Andalas
Padang, Indonesia
athaliaalfac@gmail.com

Novizon

Electrical Engineering Department,
Engineering Faculty, Universitas
Andalas
Padang, Indonesia
novizon@eng.unand.ac

Abstract—This paper presents the analysis of over-current relay coordination and the safety of the distribution system after the addition of a photovoltaic (PV) system and wind turbine generation (WTG) as intermittent distributed generation (DG). The coordination and security were assessed using ETAP simulation for 20 kV distribution network with 20 buses. In this study, power flow analysis and short circuits were conducted for relay settings and selectivity analysis. The analysis was carried out before and after the addition of a PV system and WTG. The results showed that the protective relays are coordinated appropriately, and the security of the system runs properly before the addition of the intermittent DG. However, after the addition of intermittent DG at a certain percentage of load power, the protective relays are uncoordinated and, under certain conditions, the security of the system is faulty. This condition was resolved by resetting the existing relays and by adding new relays at the intermittent DG bus. The study concludes that the addition of overcurrent relay close to DG location can improve distribution system security and make the over current relays coordinated.

Keywords— *intermittent distributed generation, relay coordination, and security assessment*

I. INTRODUCTION

Solar and wind power plants have been given attention as renewable energy generation worldwide [1]. Such attention is reasonable given that these natural resources are widely available, low cost of generation and environment-friendly, which is in line with the world's commitment to reduce greenhouse gas emissions [2]. However, the intermittent characteristic of solar and wind resources presents its own challenges, especially in integrating large-scale intermittent distributed generation (DG) into the electricity system, which constantly requires a balance between the generator supply and the load. In addition, intermittent generators have their characteristics of supply current and fault current.

Apart from that, the important thing that needs to be considered after the construction of a power plant is the availability of protective equipment. One of the most common problems in power system protection is a short-circuit fault current. Short-circuit fault current can interfere with the operation process of distributing electrical energy, damage existing equipment in the system, and endanger the existence of living things around it. Therefore, it is crucial to develop systems that can deal with the impact of the disturbance. One of them is by coordinating the relay such that the disturbances can be isolated, and, as a result, the continuity of electrical energy can be maintained.

In the presence of PV systems and WTG in the radial distribution network, it is important to ensure the coordination of protection systems runs properly and securely [3]. Several studies related to the analysis and use of over-current relays for distribution systems protection with DG have been carried out [4]. For example, over-current relay coordination for the protection of offshore wind power grid with high-voltage direct current (HVDC) connection report in [5]. Another researcher used directional over-current protection coordination for Microgrid and was investigated by employing LabVIEW simulation [6] and artificial intelligent method [7]. The research on dual setting directional over-current relays is proposed to protect meshed distribution systems with DG [8].

Other studies have discussed related to overcurrent protection for distribution systems with DG integration using directional elements [9][10]. This study, however, used phase overcurrent relay coordination without directional elements and was tested by using typical of the Indonesian 20 kV distribution system. Indonesia is located in an area that is crossed by the equator. It has a tropical climate, which has wind and solar energy potential of around 4.8 kWh/m²/day on average [11]. These types of generators will be added to the 20 kV distribution system network in Indonesia. Therefore, optimal coordination and security assessment of distribution feeders with intermittent renewable generation are important. This paper reports the optimal coordination and security assessment of a 20 kV distribution feeder with a PV and WTG distributed generation.

This study is organized as follows: section II, the data description and methods are explained. Section III describes the finding result and some discussion. This section shows the coordination and security assessment of distribution feeder with intermittent renewable generation. Finally, section IV concludes the paper. PV system and WTG are likely to be installed in the distribution system in near future, with the different characteristics between the two generators, it is necessary to evaluate the protection system operation.

II. DATA DESCRIPTION AND METHODS

A single line diagram is a diagram that connects the electric power system from the utility grid to load in one phase. A single line diagram serves as a test simulation on the system before it is applied in the field and controls the system. The single line diagram used in this study was a 20 kV radial distribution system as shown in Fig. 1. The test systems were modeled and simulated using the ETAP software. The peak load average solar irradiance and average wind speed have been used in the simulation.

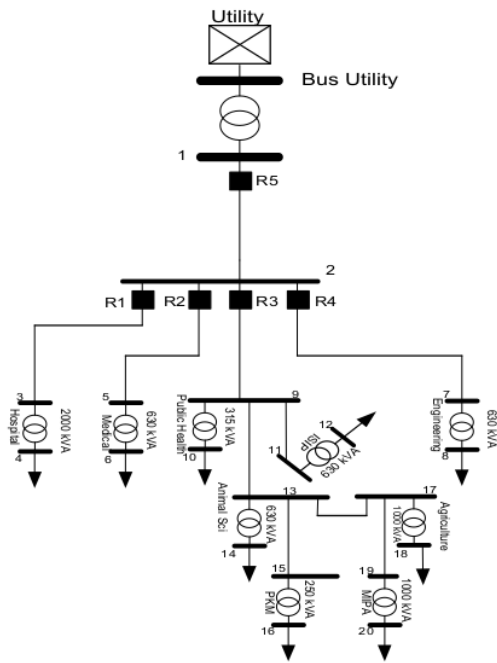

Fig 1. Single line diagram of 20 kV radial distribution system

According to the IEC 60255-3 standard [12], the operating time of the over current protection relay was calculated using (1).

$$T_{op} = \frac{\beta \times TMS}{(PSM)^{\alpha - 1}} \quad (1)$$

where:

TMS = Time Multiplier Setting

Top = Operation Time (second)

PSM = Plug Setting Multiplier

α and β = Coefficients of the time characteristic curve as specified in Table I.

The plug setting multiplier was calculated using equation (2) below:

$$PSM = \frac{I_f}{I_{pp}} \quad (2)$$

where:

I_{pp} = Iprimary pickup

I_f = Fault current (A)

The primary pickup current was calculated using the following equation (3):

$$I_{pp} = 1.2 \times I_N \quad (3)$$

and the current in secondary side was calculated using equation (4).

$$I_{\text{Secondary pickup}} = \frac{I_{\text{primary pickup}}}{\text{Ratio CT}} \quad (4)$$

The characteristic coefficients for inverse overcurrent curves are given as in Table I.

TABLE I. IEC 60255-3 CONSTANTS OF TIME CHARACTERISTIC DEGREE

Curve Type	α	β
Normal Inverse	0.02	0.14
Very Inverse	1.0	13.5
Extremely Inverse	2.0	80.0
Long time Inverse	1.0	120.0

The equations (1)-(4) above were used in calculating relay settings and ensured that the protection system was well coordinated.

III. RESULTS AND DISCUSSION

The distribution system used in this study was a radial distribution system, as shown in Fig. 1. This showed that if a disturbance took place on one of the buses, all consumers connected to the bus will be off. The initial step for the relay coordination process required the results of load flow simulation for nominal current (I_N) and short circuit for fault current (I_f) on relay placement as shown in Table I. Based on the maximum load current, the results of load flow simulation were obtained for each of the relay's pickup current using equation (3). The relay operating time with normal inverse degrees was obtained, as in Table II.

The selectivity analysis to test the coordination of the protection system at several fault locations before the addition of DG is shown in Table III. The coordination of the protection system runs properly according to the settings that were designed previously. In the event of a disturbance in the hospital feeder, if the main relay fails to work, then relay R5 will work as a backup relay. Similar processes apply to other relays connected to other feeders. Therefore, the coordination is expected to work sequentially with a predetermined setting time to secure interference.

A. Intermittent Distributed Generator Integration Scenario

The addition of DG to the radial distribution system is shown in Fig.2. When a fault occurs, it will activate DG in supplying the fault current to the location of the fault point. For this condition, additional protection is needed to secure the system.

TABLE II. RELAY SETTING BEFORE INTERMITTENT DG CONNECTED

Relay	I_N (A)	I_f (kA)	I_{pickup} (A)	TMS	T_{op} (s)
R1	9.4	4.25	11.28	0.1	0.111
R2	8.5	4.25	10.2	0.1	0.109
R3	37	4.178	44.4	0.1	0.147
R4	7	4.07	8.4	0.1	0.106
R5	61.3	4.66	77.56	0.647	0.4

Note: CT ratio 100:1

TABLE III. RELAY COORDINATION AND SYSTEM SECURITY WITHOUT INTERMITTENT DG

Fault Location	Relay function		Coordinated	Security
	Main	Back Up		
Bus 3	R1	R5	Yes	Secure
Bus 5	R2	R5	Yes	Secure
Bus 9	R3	R5	Yes	Secure
Bus 7	R4	R5	Yes	Secure
Feeder 2-5	R2	R5	Yes	Secure

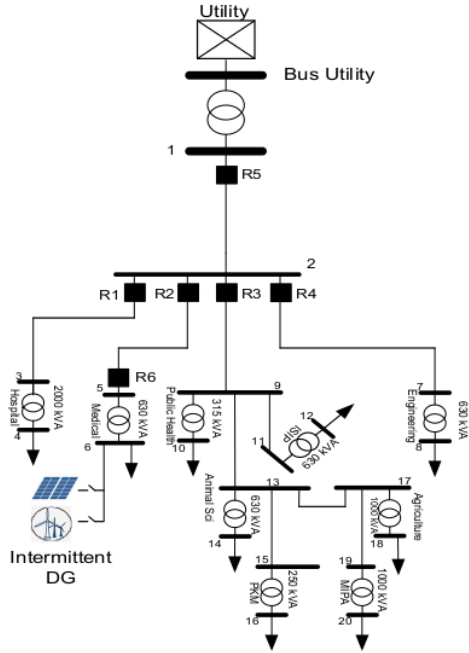

Fig 2. Single line diagram of 20 kV radial distribution system with Intermittent DG

First scenario: a medical bus is tested by adding a wind turbine to see the suitability of the relay coordination.

At a power percentage ranging from 5% to 25%, the relay coordination did not work properly. It is due to the fact that when a disturbance occurs in one of the feeders, the relay in the medical bus feeder does not work. Consequently, the relay coordination does not run as it should. The relay on the medical feeder will work because of the current supply from WTG. This case occurs because the value of the fault current does not reach the setting current of the relay.

Table IV shows the relay setting for current and fault current after wind turbine added. Based on this, the fault current on the medical bus feeder does not exceed the relay setting current. As a result, at a power percentage of 5% to 25%, the relay on the medical bus feeder does not work. However, when the power percentage reaches 30% more, the relay on the medical feeder works properly. This is because the fault current value exceeds the relay setting current value, causing the relay on the medical bus feeder to work and the relay coordination work as it should.

TABLE IV. RELAY COORDINATION TESTING AFTER ADDING WIND TURBINE AT BUS 6

WT Injection		I _{set} (A)	I _r (A)	Coordinated	R2 Status
(%)	kW				
5	15.1	10.2	1	No	Not trip
10	30.2	10.2	3	No	Not trip
15	45.3	10.2	6	No	Not trip
20	60.4	10.2	8	No	Not trip
25	75.5	10.2	10	No	Not trip
30	90.6	10.2	11	Yes	Trip
40	120.8	10.2	15	Yes	Trip

TABLE V. RELAY COORDINATION TESTING AFTER ADDING PV TO THE 6 BUS

Load (kVA)	PV Injection		I _{set} (A)	I _r (A)	Coordinated	R2 Status
	(%)	kW				
302	5	16.48	10.2	1	No	Not trip
302	10	29.66	10.2	1	No	Not trip
302	15	46.13	10.2	2	No	Not trip
302	20	59.32	10.2	3	No	Not trip
302	25	75.79	10.2	3	No	Not trip
302	30	92.27	10.2	5	No	Not trip
302	40	12.9	10.2	6	No	Not trip
302	50	15.6	10.2	6	No	Not trip
302	60	18.2	10.2	8	No	Not trip
302	70	210.9	10.2	9	No	Not trip
302	80	240.6	10.2	11	No	Not trip
302	90	273.5	10.2	11	Yes	Trip
302	100	303.2	10.2	11	Yes	Trip

Note: CT ratio 100:1

Second scenario: a test is carried out on a medical bus by adding a PV system to see the suitability of the relay coordination.

At a power percentage ranging from 5% to 80%, the relay coordination does not work properly. A disturbance occurring in one of the feeders caused this resulting in the relay in the medicine feeder does not work. Consequently, the relay coordination does not work as it should. The relay on the medical bus feeder will work if there is current supply from the PV. This is because the value of the fault current does not reach the relay setting current. This causes the relay on the medical bus feeder failed to work, as shown in Table V.

A conclusion can be drawn that the failure of the relay on the medical bus feeder is caused by the fault current which does not exceed the relay setting current. As a result, at a power percentage ranging from 5% to 80%, the relay on the medical bus feeder does not work. However, if the power percentage increases up to more than 90%, the relay on the medical bus feeder will work. This is because the fault current value exceeds the relay setting current value, causing the relay on the medical bus feeder to work and relay coordination runs as it should.

Third scenario: a test is carried out on the medical bus feeder by adding both WTG and PV to see whether or not the relay coordination works. At a power percentage ranging from 5% to 20%, the relay coordination does not work properly. This is caused by a disturbance occurring in one of the feeders, resulting in the relay in the medical bus feeder does not work. Consequently, the relay coordination does not work as it should. The relay on the medical bus feeder will work if there is current supply from the PV. This is caused by the fact the value of the fault current does not reach the relay setting current, which causes the relay on the medical bus feeder fail to work, as shown in Table VI.

TABLE VI. RELAY COORDINATION TESTING AFTER ADDING WTG AND PV AT BUS 6

WT (kW)	PV (kW)	I _{set} (A)	I _r (A)	Coord	R2 Status
15,1	16.48	10.2	2	No	Not trip
30,2	29.66	10.2	4	No	Not trip
45,3	46.13	10.2	7	No	Not trip
60,4	59.32	10.2	9	No	Not trip
75,5	75.79	10.2	11	Yes	Trip
90,6	92.27	10.2	13	Yes	Trip

This indicates that the failure of the relay on the medical bus feeder is caused by the fault current, which does not exceed the relay setting current. As a result, at a power percentage ranging from 5% to 20%, the relay on the medical bus feeder does not work. However, when the power percentage goes up to 25% or more, the relay will work. This is because the fault current value exceeds the relay setting current value, causing the relay on the Medicine feeder to work and relay coordination as it should.

This also shows that the main factor that affects the magnitude of the fault current is the 25% addition of WTG. The relay will work lower than 30%. This is because of a little additional fault current from the PV system. Therefore, the relay works at a percentage of 25% WTG. After DG in the form of WTG and PV is added, the relay coordination comes with varying fault currents, showing the suitability of relay coordination.

Table VII shows that the relay coordination runs properly if there is a disturbance on the hospital, medical, nursing, and engineering buses. However, if feeder 2-5 and bus 5 are disturbed, the relay coordination works properly, but the system is not secure. This is because when a disturbance occurs in feeder 2-5, there is a fault current still flow from DG, causing system security to not work properly. In such a case, additional relays are needed on DG location in order that interference from DG can be isolated.

B. Added over current relay at bus close to DG location

In this part, the new protective relay added at bus close to DG location were tested and analyzed. Before the relay added, the system safety still has problem, a disturbance is not yet isolated in the medical feeder. To resolve this, additional relays are needed by adding an over current relay near the medical bus transformer and between the primary and secondary medical bus.

The new setting of the additional relays R6 and resetting of other relays follows the equation (1), (2), (3) and (4), have been obtained and show in Table VIII. The primary pickup current, time multiplier setting as well operating time of protective relay all cases were shown in the table. After setting the additional relays and resetting the other relays, the coordination of the relay and system safety is shown following the addition of DG in the form of wind and solar power plants, as shown in Table IX.

Based on Table IX after resetting (R1-R5) and a new setting for relay R6, the relay coordination runs properly, and so does the system security, when the fault occurs at feeder 2-5, also works well. The reason for this is that the disturbance is protected by relay R6, which serves as a reserve if relay R2 fails to work. The fault current from PLN grid and the injection fault current from DG in downstream both isolated by R5 and R6 operated.

TABLE VII. RELAY COORDINATION AND SYSTEM SECURITY BEFORE RESETTING

Fault Location	Relay function			Coordinated	Security
	Main	Back Up			
Bus 3	R1	R5	R2	Yes	Secure
Bus 5	R2	R5	-	Yes	Not Secure
Bus 9	R3	R5	R2	Yes	Secure
Bus 7	R4	R5	R2	Yes	Secure
Feeder 2-5	R2	R5	-	Yes	Not secure

TABLE VIII. RELAY SETTING AFTER INTERMITTENT DG CONNECTED

Relay	PV		
	I _p (A)	TMS	T _{op} (s)
R1	11.28	0.1	0.111
R2	4.32	0.1	0.094
R3	44.4	0.1	0.147
R4	8.4	0.1	0.106
R5	66.24	0.41	0.647
R6	8.64	1.21	1.147
Relay	WT		
	I _p (A)	TMS	T _{op} (s)
R1	11.28	0.1	0.111
R2	8.64	0.1	0.106
R3	44.4	0.1	0.147
R4	8.4	0.1	0.104
R5	71.64	0.72	1.147
R6	8.64	1.108	1.147
Relay	PV+WT		
	I _p (A)	TMS	Top (s)
R1	11.28	0.1	0.111
R2	6.96	0.1	0.102
R3	44.4	0.1	0.147
R4	8.4	0.1	0.106
R5	69.24	0.405	0.647
R6	6.96	1.122	1.147

TABLE IX. RELAY COORDINATION TESTING AFTER ADDING NEW OCR AT INCOMING BUS 5

Fault Location	Relay function				Coordinated/ Secure
	Main	Backup			
Bus 3	R1	R5	R2	R6	Yes/secure
Bus 5	R2	R5	-	R6	Yes/secure
Bus 9	R3	R5	R2	R6	Yes/secure
Bus 7	R 4	R5	R2	R6	Yes/secure
Feeder 2-5	R 2	R 5	-	R6	Yes/secure

IV. CONCLUSIONS

The addition of DG in the form of a wind turbine, PV, or both WT and PV may cause a change in relay coordination. This is because the value of the fault current does not exceed the value of the relay pickup current setting. As a result, the relay R2 in the feeder, with added DG, does not work and the relay coordination does not match properly. The size of DG gives impact on the system security, especially for WT, which produces considerable fault current contribution compared to PV DG added. The addition of a new relay R6 on the bus adjacent to the DG location can solve the security problem mentioned above. If a fault occurs on feeder 2-5, additional protection is needed in the form of an OCR to secure the interference from DG if relay R2 fails to work. Therefore, the addition of an OCR at a location close to DG enables a secured interference on the medical bus feeder. Accordingly, if a disturbance occurs, the security of the system also improves.

ACKNOWLEDGMENT

This research was funded by Universitas Andalas under The 2021 Riset Publikasi Bereputasi Research (RPB) scheme with Contract No. T/24/UN.16.17/PT.01.03/Energi-RPB/2021.

REFERENCES

- [1] Syafii and K. M. Nor, "Renewable distributed generation models in three-phase load flow analysis for smart grid," *Telkomnika*, vol. 11, no. 4, 2013.
- [2] M. S. Islam, B. K. Das, P. Das, and M. H. Rahaman, "Techno-economic optimization of a zero emission energy system for a coastal community in Newfoundland, Canada," *Energy*, vol. 220, p. 119709, 2021.
- [3] S. D. Saldarriaga-Zuluaga, J. M. López-Lezama, and N. Muñoz-Galeano, "An approach for optimal coordination of over-current relays in microgrids with distributed generation," *Electron.*, vol. 9, no. 10, pp. 1–15, 2020.
- [4] N. El Nailly, S. M. Saad, S. Abeid, and H. Saleh, "Improved over-current coordination using artificial intelligence in benghazi MV-Distribution network case study," in *ACM International Conference Proceeding Series*, 2020.
- [5] S. K. Chaudhary, R. Teodorescu, P. Rodriguez, and P. C. Kjær, "Over-current relay coordination for the protection of offshore wind power grid with HVDC connection," in *European Wind Energy Conference and Exhibition 2012, EWEC 2012*, 2012, vol. 2, pp. 759–765.
- [6] M. Abubakar, M. Sarwar, T. H. Khan, M. Sarmad, and B. Hussain, "Real-time Implementation of Directional Over-current Protection Coordination in a Microgrid," in *RAEE 2018 - International Symposium on Recent Advances in Electrical Engineering*, 2018.
- [7] S. Pil Ramli, H. Mokhlis, W. R. Wong, M. A. Muhammad, N. N. Mansor, and M. H. HUSSAIN, "Optimal coordination of directional overcurrent relay based on combination of improved particle swarm optimization and linear programming considering multiple characteristics curve," *Turkish J. Electr. Eng. Comput. Sci.*, pp. 1765–1780, 2021.
- [8] H. H. Zeineldin, H. M. Sharaf, D. K. Ibrahim, E. E.-D. A. El-Zahab, and E. E. Abou El-Zahab, "Optimal protection coordination for meshed distribution systems with DG using dual setting directional over-current relays," *IEEE Trans. Smart Grid*, vol. 7, no. 3, pp. 115–123, 2016.
- [9] H. M. Sharaf, H. H. Zeineldin, D. K. Ibrahim, and E. E.-D. A. EL-Zahab, "A proposed coordination strategy for meshed distribution systems with DG considering user-defined characteristics of directional inverse time overcurrent relays," *Int. J. Electr. Power Energy Syst.*, vol. 65, pp. 49–58, 2015.
- [10] S. Pil Ramli et al., "Optimal directional overcurrent relay coordination based on computational Intelligence technique: a review," *Turkish J. Electr. Eng. Comput. Sci.*, pp. 1284–1307, 2021.
- [11] Syafii, A. B. Pulungan, Wati, and R. Fahreza, "Techno-Economic Analysis of Tracker Based Rooftop PV System Installation Under Tropical Climate," *Int. J. Adv. Trends Comput. Sci. Eng.*, vol. 9, no. 4, p. [In Press], 2020.
- [12] B. S. Paithankar YG, *Fundamentals of Power System Protection*. New Delhi, India: PHI Learning Pvt. Ltd, 2011.

Coordination and Security Assessment of Distribution Feeder with Intermittent Renewable Generation

ORIGINALITY REPORT

6%

SIMILARITY INDEX

3%

INTERNET SOURCES

7%

PUBLICATIONS

4%

STUDENT PAPERS

PRIMARY SOURCES

- | | | |
|---|--|----|
| 1 | Submitted to Griffith University
Student Paper | 1% |
| 2 | "[Copyright notice]", 2021 International Conference on Technology and Policy in Energy and Electric Power (ICT-PEP), 2021
Publication | 1% |
| 3 | "Program Information", 2021 International Conference on Technology and Policy in Energy and Electric Power (ICT-PEP), 2021
Publication | 1% |
| 4 | Syafii, Amirul Luthfi, Novizon, Rahmad Fahreza. "Cost of Energy Sensitivity Analysis of PV/Diesel with Hydro Pumped Storage for Mentawai Microgrid System", 2021 IEEE 4th International Conference on Computing, Power and Communication Technologies (GUCON), 2021
Publication | 1% |
| 5 | Submitted to Nanyang Technological University, Singapore | 1% |

6

Tohid Soleymani Aghdam, Hossein Kazemi Karegar, Hatem H. Zeineldin. "Transient Stability Constrained Protection Coordination for Distribution Systems With DG", IEEE Transactions on Smart Grid, 2018

Publication

1 %

Exclude quotes On

Exclude matches < 1%

Exclude bibliography On