

Web-based Net Energy Meter for Grid Connected PV System

Syafii Syafii, Muhammad Ilhamdi Rusydi, Lovely Son, Irvan Zikri

Electrical Engineering Department, Faculty of Engineering, Universitas Andalas, Padang, Indonesia

Abstract – The web-based PV system monitoring to measure electrical production and consumption to the load or utility grid is presented in this paper. This monitoring system consists of an Arduino Mega 2560 with two PZEM 004T sensor modules. The monitoring system has been designed to store measurement data of current, voltage, power and energy in the database and display on the webpage in real time and infographics history. The PZEM sensor measurement has been tested with an average power difference 0.29% less than IEC-61724 minimum-accuracy. Realtime data is obtained in the form of one-line data for every 2 seconds, with a data size of 375-byte and 75ms delivery delay. For one day period testing, the electrical energy that can be generated by the PV system is 5,925 kWh, while the power consumed by the load is only 1,272 kWh so the accumulated electrical energy that can be exported is 4.65 kWh. The test results show that the system has been able to measure net energy export or import by the PV system to utility grid.

Keywords – Web-based PV monitoring, Arduino PZEM sensors, and Grid connected PV system.

1. Introduction

Increasing electricity demand affects in diminishing energy reserves. Indonesia, with the greatest potential for solar energy through the government regulation No. 14, 2012 provides an opportunity for owners to connect their PV Systems into national utility network.

DOI: 10.18421/TEM91-06

<https://dx.doi.org/10.18421/TEM91-06>

Corresponding author: Syafii Syafii,
Electrical Engineering Department, Universitas Andalas.
Email: syafii@eng.unand.ac.id

Received: 26 September 2019.

Revised: 24 December 2019.

Accepted: 06 January 2020.

Published: 28 February 2020.

 © 2020 Syafii Syafii at al; published by UIKTEN. This work is licensed under the Creative Commons Attribution-NonCommercial-NoDerivs 3.0 License.

The article is published with Open Access at www.temjournal.com

Utilization of PV system in distribution network requires bidirectional power meter to evaluate the amount of electrical energy produced and the burden used to reduce electricity bill. Therefore, the utilization of communication technology, sensors, and information to distributed generation metering and control are the topics of interest in the development of future smart grid [1],[2].

Several previous studies have discussed various techniques for electrical energy production and consumption monitoring. The research on integrated data-acquisition system for photovoltaic blocks mutualization monitoring using LabView [3], remote monitoring system based on GSM data communication network for rural areas [4], LoRa wireless sensor networks [5],[6] and web-based through internet networks [7],[8], have been done and reported. In a study conducted in [9], a Web-Scada was implemented to monitor and control solar-wind hybrid generator systems remotely through the internet and based on LabView software via RS232 serial communication [10]. The connection to the internet network is done through a server computer with communication between sensors, remote terminals, and the server computers in the study use serial communication wired networks and Local Area Networks.

This paper presents the proposed web-based net energy meter system using two PZEM 004T modules based on Arduino microcontroller. The monitoring system is designed in real time measurement and record in historical online data. So that the data obtained can be monitored anytime anywhere and saved for further analysis. The electrical data from the power produced by the PV system and the power used in the load demand with the utility grid are obtained through PZEM 004T sensors measurements. The results of this study are expected to help obtain the use of electrical energy and energy generated by PV system in real time and historical online data, displayed on websites that can be accessed anytime and anywhere, so as to optimize the use of electrical energy to be more efficient.

2. Hardware and Software of Web-Based PV Monitoring

The web-based net energy monitoring system is used to collect the electricity and energy generated by PV system in real time and online. The collected data is displayed on a website that can be accessed anytime and anywhere for further evaluation, optimized and made more efficient. The monitoring system consists of two important parts hardware and software.

The web-based monitoring system consists of three main hardware components i.e: an Arduino Mega 2560, two PZEM 004T sensor modules and an Ethernet shield. PZEM 004T is a sensor used to measure single phase voltage, current, power and electrical energy. The PZEM-004T uses SD3004 energy measurement SoC chip from SDIC microelectronics, which has very good measurement accuracy. This PZEM 004T operates for the use of active energy with a frequency of 50 Hz and 60 Hz in one phase of the circuit. This tool is equipped with 4 PINs that function as voltage and current input, 2 serial communication PINs and 2 PINs as a voltage and current source to operate the sensor. In this sensor, in measuring the flow carried out by the installation of CT in one of the input circuits, the ratio of the number of turns on CT is 1000: 1.

Ethernet shield is one of the Arduino output devices for connecting Arduino microcontrollers with internet networks. Ethernet shield uses a Wiznet W5100 chip that is able to provide network via an IP address so that Arduino can communicate with TCP or UDP. The Ethernet shield uses an RJ45 cable as a data transmission path. It is also equipped with an SD Card adapter that serves to store data via an SD Card. In operating the Ethernet Shield, communication is carried out serially through the SPI (Serial Peripheral Interface) bus. The four SPI signals on the Arduino Mega 2560 are Master in Slave Out (MISO) on PIN 51, Master Out Serial In (MOSI) on PIN 50, Serial Clock (SCLK) on PIN 52 and Chip Select (CS) on PIN 10.

Programming is done to read data from the PZEM sensor using the Arduino IDE based on C ++ language structure, so that it can connect between Arduino and PZEM 004T sensors and Ethernet Shield. Next, executing programming arguments, the digital data obtained by Arduino is using the PHP programming language, while for data storage is done with MySQL database management. Then it is displayed in the form of infographics on the website using Javascript programming language and HTML marking language, so that it becomes more interactive and can be displayed in real time.

The software is used in the monitoring process to collect, save, process and display data in an

interactive and attractive manner for the user. These techniques are known as internet of things (IoT) architecture which consists of: retrieving data in the perception layer, storing and computing data in the network layer, and displaying data in interactive form (graphics or animation) to users on the application layer [13],[12].

3. System Design

The system will read the voltage, current, and RMS power at the inverter output and load using the PZEM 004T sensor. Then the data is sent using a TTL cable to Arduino with TTL serial communication. After the data is obtained on Arduino, it is processed based on algorithm calculation and comparison then uploaded to the website database using Ethernet Shield that has been connected to the internet network. After the data has been uploaded to the database, the measurement data can be displayed in real time on the website.

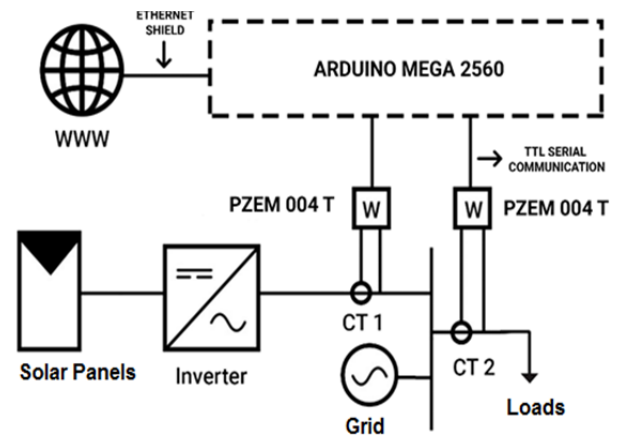

Figure 1. PZEM Based Net Energy Meter

Programming is done using the Arduino IDE which uses the C ++ language structure to write programs into Arduino, so that it can connect between Arduino and PZEM 004T sensors and Ethernet Shield. The program for website creation is done using PHP language to connect between databases and website views. The database programming language uses the MySQL language and real-time readings from the website so that it becomes interactive using HTML, CSS and the Javascript programming language. Thus, users can access to get information of their energy consumption via web application locally or via Internet. The system overview is shown in Fig. 1.

This monitoring system test is carried out in the electrical engineering department which has a solar power plant connected to the grid using an grid-tie inverter. The inverter will be monitored along with the amount of load connected so that the type of power flow used by the load is obtained. Testing

system components consist of two parts, namely testing with hardware and testing with software. The system hardware is tested based on the installation of Arduino Mega 2560 and PZEM 004T pins or cables that are following the design. The system software tested using Arduino IDE and Google Chrome Developer Tools. The Arduino program tested using Arduino IDE using monitor serial output parameters, while on servers and clients it is tested using Google Chrome Developer Tools software with output parameters on the network.

The overall system is designed as shown in Fig. 2 below.

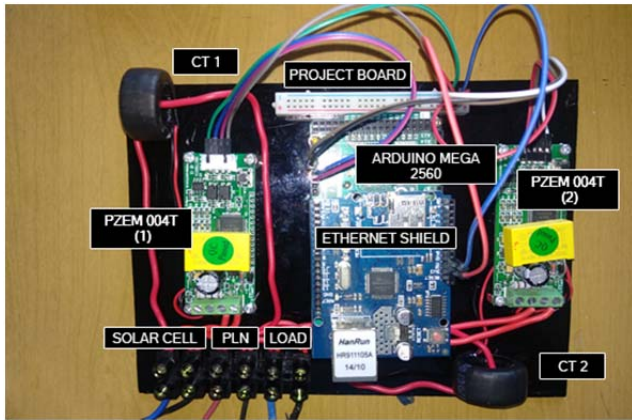

Figure 2. Web-based Net Energy Meter Real Circuit

4. Result and Discussion

The PZEM 004T test used to determine the sensor configuration system with the Arduino Mega 2560 microcontroller. This aim has been achieved. The operation of the sensor required four TTL cables consisting of one 5V voltage operating cable, one ground cable, and a pair of cables that function as senders (TX) and data receivers (RX) with serial communication lines as shown in Fig. 3.

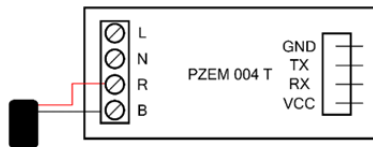

Figure 3. Schematic diagram of PZEM 004T

Hardware testing is carried out by installing cables directly through GND, TX, RX, and VCC pins on pins that are available on Arduino Mega 2560. Installation of two or more PZEM 004T requires a project board to connect in parallel between VCC pins and GND. The PZEM Pin connection is shown in Table 1.

PZEM 004T (1) is installed in Arduino Mega 2560 Serial 2, and PZEM 004T (2) is installed in Arduino Mega 2560 Serial 1 while VCC and GND on each

sensor are connected in parallel through the project board. When the Grid tie inverter successfully synchronizes with low voltage distribution grid, then PZEM 004T (1) and (2) will directly transmit voltage, current, power and energy data to Arduino Mega 2560 as real digital values.

Table 1. PZEM Connection

Component	Init Pin	Final Pin	Note
PZEM 004T (1)	VCC	VCC on project board	5 V
	GND	GND on project board	negative polarity of circuit
	TX	Pin 17 Arduino (RX Serial 2)	PZEM 004T (1) Transceiver data to Arduino
	RX	Pin 16 (TX Serial 2)	Receiver data of PZEM 004T (1) from arduino
PZEM 004T (2)	VCC	VCC on project board	5 V
	GND	GND on project board	negative polarity of circuit
	TX	Pin 19 (RX Serial 1)	PZEM 004T (2) Transceiver data to Arduino
	RX	Pin 18 (TX Serial 1)	Receiver data of PZEM 004T (2) from arduino

The PZEM 004T digital reading is done by the serial communication with Arduino Mega 2560 to get the amount of voltage, current, power and energy as show in Fig. 4. By the comparison of PZEM 004T measurement and Hioki 3286-20 Clamp Meter, can be concluded that the PZEM 004T sensor (1) and (2) have worked well because the measured value is close to the measured value of Hioki 3286-20 Clamp Meter with an average power difference of 0, 29%. Based on IEC-61724 standard [11] this value is acceptable because the accuracy is less than 1 %. Therefore, data obtained from current, voltage, power and energy of PZEM sensor can be used for PV system monitoring.

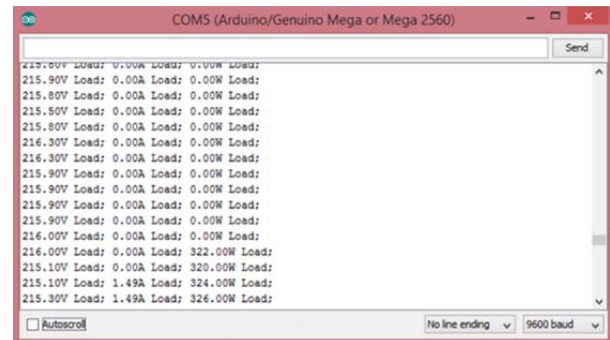

Figure 4. Data read by PZEM 004T

Data obtained from each sensor will be stored in the Arduino Mega 2560 program variable. The

difference reading data of two PZEM will be evaluated for determining the power state at the load, whether in the import or export status. The export or import status will be displayed in the monitoring system through internet network access.

Fig.5 shows the three days measurement data that the acquisition of data from the system works well by sending data as much as 926 data with time delay for storing data on average is 4 minutes 40 seconds. Testing on the server is done by sending data to the

client, while testing on the client is to display the data into real time and infographics Fig 5. During testing, the data server is sent by changing the variable values that have been stored in the database into the JSON data exchange format. Testing servers is done with clients using Google Chrome Developer Tools software. The data obtained is then displayed on the website with the AJAX feature so that JSON data can be updated regularly without having to refresh the website page continuously.

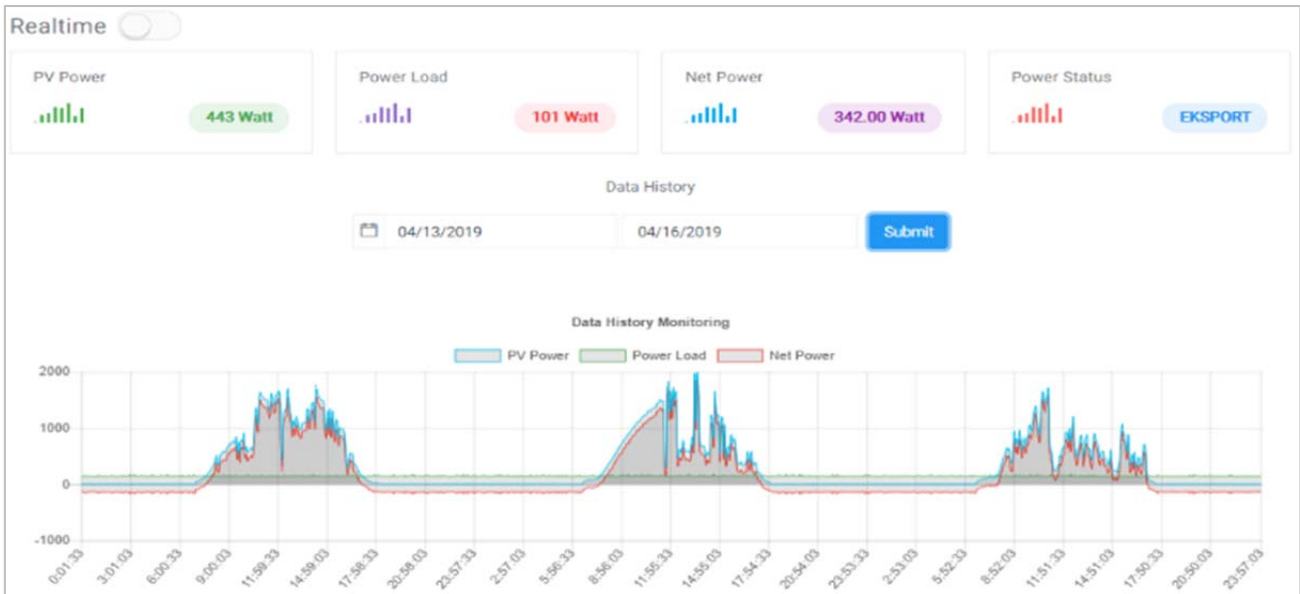

Figure 5. Display of real-time and historical data monitoring

Website display shows data in real time conditions at 10:37 WIB, PLTS will generate power of 443 Watts, with the condition of the load usage at that time 101 watts, the excess power of 342-watts will then be sent to the utility network as export power. Historical data testing for three days shows that the

current generated by PV system will be Export status at 6.00 am until reaching the peak at 12 am, then it will decrease and turn into Import status at 6.00 pm. However, weather conditions and load demand are important factors in determining the export/import status of electrical energy of the utility grid.

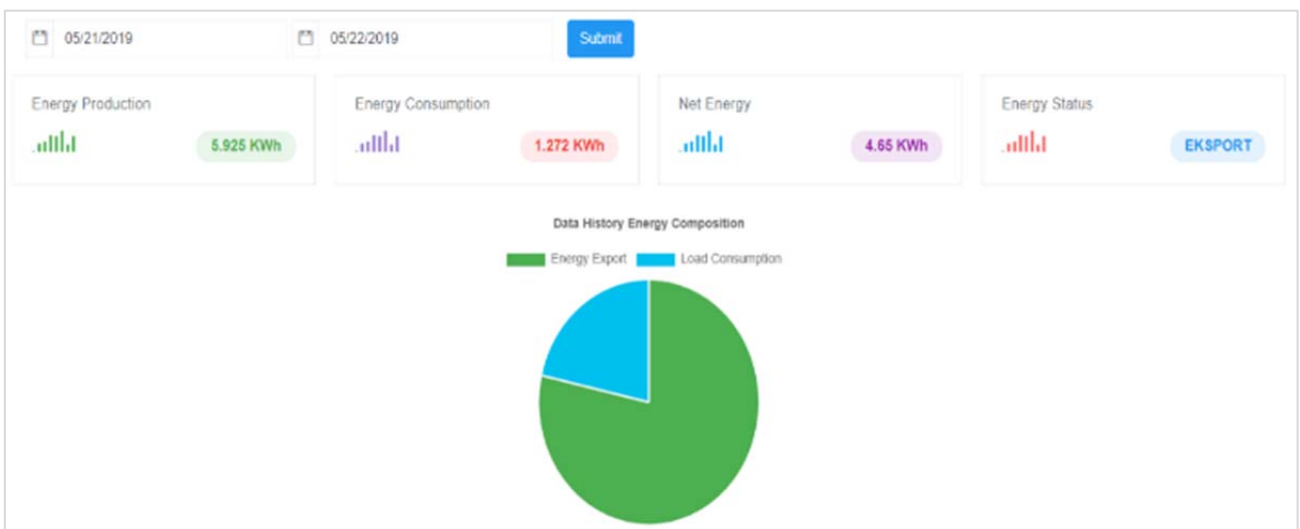

Figure 6. Pie chart of Energy production, consumption and status import/export display

The accumulation of power collected for a certain time will be calculated as energy. The measurement results have been displayed in the form of infographics to show the composition of energy use and energy production as well as net energy in one day period from 05/21/2019 to 05/22/2019 as shown in Fig. 6. For one day measurement the energy that can be generated by the PV system is 5,925 kWh, while the power consumed by the load is only 1,272 kWh, so the accumulated electrical energy that can be exported is 4.65 kWh.

5. Conclusion

The net energy meter system has read voltage, current, power and energy generated at the inverter output terminal and load terminal using the PZEM 004T sensors. Based on these data the net energy export to utility or import from utility can be determined. This system is equipped with a data logger feature, so the measurement data can be directly recorded on the client computer. The PZEM 004T obtained data have a good level of accuracy with an average power difference of 0.29% compared with Hioki 3286-20 clamp meter. For one day measurement the energy that can be generated by the PV system is 5,925 kWh, while the power consumed by the load is only 1,272 kWh so the accumulated electrical energy that can be exported is 4.65 kWh. Based on these data, further investigation to calculate the energy costs per kWh produced by a solar power plant, saving the electrical energy obtained and the length of investment costs return time achieved can be performed.

Acknowledgements

The authors gratefully acknowledge the assistance rendered by Directorate General of Higher Education and Universitas Andalas for the research and publication financial support.

References

- [1]. Sharma, K., & Saini, L. M. (2017). Power-line communications for smart grid: Progress, challenges, opportunities and status. *Renewable and Sustainable Energy Reviews*, 67, 704-751.
- [2]. Labib, L., Billah, M., Rana, G. S. M., Sadat, M. N., Kibria, M. G., & Islam, M. R. (2017). Design and implementation of low-cost universal smart energy meter with demand side load management. *IET Generation, Transmission & Distribution*, 11(16), 3938-3945.
- [3]. Mezouari, A., Mateur, K., Alareqi, M., Hlou, L., & Elgouri, R. (2017, April). Development of an integrated data-acquisition system for photovoltaic blocks mutualization monitoring using LABVIEW. In *2017 International Conference on Wireless Technologies, Embedded and Intelligent Systems (WITS)* (pp. 1-4). IEEE.
- [4]. Tejwani, R., Kumar, G., & Solanki, C. S. (2016). Remote monitoring of solar PV system for rural areas using GSM, VF & FV converters. *Journal of Instrumentation*, 11(05), P05001.
- [5]. Shuda, J. E., Rix, A. J., & Booyesen, M. J. (2018, June). Towards Module-Level Performance and Health Monitoring of Solar PV Plants Using LoRa Wireless Sensor Networks. In *2018 IEEE PES/IAS PowerAfrica* (pp. 172-177). IEEE.
- [6]. Paredes-Parra, J. M., García-Sánchez, A. J., Mateo-Aroca, A., & Molina-García, Á. (2019). An alternative Internet-of-Things solution based on LoRa for PV power plants: data monitoring and management. *Energies*, 12(5), 881.
- [7]. Kopacz, C., Spataru, S., Sera, D., & Kerekes, T. (2014, May). Remote and centralized monitoring of PV power plants. In *2014 International Conference on Optimization of Electrical and Electronic Equipment (OPTIM)* (pp. 721-728). IEEE.
- [8]. Saraiva, L., Alcaso, A., Vieira, P., Ramos, C. F., & Cardoso, A. M. (2016). Development of a cloud-based system for remote monitoring of a PVT panel. *Open Engineering*, 6(1), 291-297.
- [9]. Soetedjo, A., Nakhoda, Y. I., & Lomi, A. (2014). Web-SCADA for monitoring and controlling hybrid Wind-PV power system. *Telkomnika*, 12(2), 305-314.
- [10]. Anwari, M., Dom, M. M., & Rashid, M. I. M. (2011). Small scale PV monitoring system software design. *Energy Procedia*, 12, 586-592.
- [11]. IE Commission. (2017). Photovoltaic system performance monitoring-guidelines for measurement, data exchange and analysis-Part 1: monitoring. *Int. Stand. IEC*, 1-10.
- [12]. Miškuf, M., Kajáti, E., & Zolotová, I. (2017). Smart metering IoT solution based on NodeMCU for more accurate energy consumption analysis. *International Journal of Internet of Things and Web Services*, 2, 115-121.
- [13]. Pereira, R. I., Dupont, I. M., Carvalho, P. C., & Jucá, S. C. (2018). IoT embedded linux system based on Raspberry Pi applied to real-time cloud monitoring of a decentralized photovoltaic plant. *Measurement*, 114, 286-297.