

Publish with us

[Submit an article](#) ▾

Start a new manuscript submission or continue a submission in progress

[Go to submission site](#) ↗

Submission information

[Instructions for authors](#)

[Editorial policies](#) ↗

Explore

[About this journal](#) ▾

[Browse all articles & issues](#) ▾

[Latest issue](#)

Subscribe

[Alerts & RSS feed](#) ▾

[Purchase a subscription](#)

Journal metrics



Usage

- **174K** annual downloads/views



Citation metrics

- **2.141 (2020)** Impact Factor
- **2.011 (2020)** 5 year IF
- **3.6 (2020)** CiteScore
- **Q1 (2020)** CiteScore Best Quartile
- **1.223 (2020)** SNIP
- **0.403 (2020)** SJR

Computer science Journals

>> [Sign in here](#) to start your account to the latest two volumes for 14 o

Understanding and using journal metrics

Ready to submit?

Start a new manuscript submission or continue a submission in progress

[Go to submission site](#) ↗

Submission information

[Instructions for authors](#)

Editorial board

CHIEF EDITOR

Danuta Koradecka

Central Institute for Labour Protection – National Research Institute (CIOP-PIB)
ul. Czerniakowska 16, 00-701 Warszawa, Poland

CO-EDITOR

Waldemar Karwowski

University of Central Florida

Submission information

[▶ Instructions for authors](#)

[▶ Editorial policies](#)

Editing services

[▶ Editing services site](#)

About this journal

[▶ Journal metrics](#)

[▶ Editorial board](#)

[▶ News & call for papers](#)

[▶ Related websites](#)

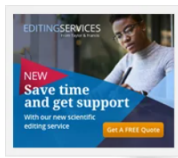

CO-EDITOR

Waldemar Karwowski

University of Central Florida

USA

CO-EDITOR

Jukka Takala

Tampere University

Finland

MANAGING EDITOR

Roman Broszkiewicz

STATISTICS EDITOR

Marcin Kozak

University of Information Technology and Management in Rzeszów

ul. Sucharskiego 2, 35-225 Rzeszów, Poland

ASSOCIATE EDITORS

Central Institute for Labour Protection – National Research Institute (CIOP-PIB), Poland

Grażyna Bartkowiak

Joanna Bugajska

Marek Dźwiarek

Maria Konarska

Elżbieta Łastowiecka-Moras

[Home](#) ▶ [All Journals](#) ▶ [International Journal of Occupational Safety and Ergonomics](#) ▶ [List of Issues](#) ▶ [Volume 23, Issue 3](#)

International Journal of Occupational Safety and Ergonomics

Enter keywords, authors, DC

This Journal



[Advanced search](#) [Citation search](#)

Publish with us
[Submit an article](#)

[About this journal](#)

Explore

[Browse all articles & issues](#)

[Latest issue](#)

Subscribe

[Alerts & RSS feed](#)

[+ Purchase a subscription](#)



International Journal of Occupational Safety and Ergonomics, Volume 23, Issue 3 (2017)

[◀](#) **Volume 23, 2017**

[Vol 22, 2016](#)

[Vol 21, 2015](#) [▶](#)

[See all volumes and issues](#)

[◀](#) Issue **4** **Issue 3** Issue **2** Issue **1** [▶](#)

[Browse this journal](#)

Article
Ergonomics intervention on an alternative design of a spinal board >
 Hilma Raimona Zadry, Lusi Susanti & Dina Rahmayanti
 Pages: 393-403
 Published online: 14 Apr 2016
 Abstract | Full Text | References | PDF (882 KB)|

223 Views
 2 CrossRef citations
 0 Altmetric

Article
Job stress dimension and work-related musculoskeletal disorders among southeast Nigerian physiotherapists >
 Ukachukwu Okoroafor Abaraogu, Charles Ukachukwu Ezema & Chigozie

433 Views
 12 CrossRef citations

223 Views
 2 CrossRef citations to date
 0 Altmetric

Ergonomics intervention on an alternative design of a spinal board

Hilma Raimona Zadry ✉, Lusi Susanti & Dina Rahmayanti
 Pages 393-403 | Accepted author version posted online: 08 Mar 2016, Published online: 14 Apr 2016

Download citation | <https://doi.org/10.1080/10803548.2016.1156843> | Check for updates

Full Article | Figures & data | References | Citations | Metrics | Reprints & Permissions | Get access

Abstract

A spinal board is the evacuation tool of first aid to help the injured spinal cord. The existing spinal board has several weaknesses, both in terms of user comfort and the effectiveness and efficiency of the evacuation process. This study designs an ergonomic spinal board using the quality function deployment approach. A preliminary survey was conducted through direct observation and interviews with volunteers from the Indonesian Red Cross. Data gathered were translated

Related research

People also read	Recommended articles	Cited by 2
<p>Prehospital Protocols Reducing Long Spinal Board Use Are Not Associated with a Change in Incidence of Spinal Cord Injury ></p> <p>Franco Castro-Marin et al. Prehospital Emergency Care</p>		

Sample our Built Environment Journals
 >> Sign in here to start your access to the latest two volumes for 14 days

Maximise the potential of your Sociology research with F1000Research



Ergonomics Intervention on an Alternative Design of a Spinal Board

Hilma Raimona Zadry, Lusi Susanti & Dina Rahmayanti

To cite this article: Hilma Raimona Zadry, Lusi Susanti & Dina Rahmayanti (2016): Ergonomics Intervention on an Alternative Design of a Spinal Board, International Journal of Occupational Safety and Ergonomics

To link to this article: <http://dx.doi.org/10.1080/10803548.2016.1156843>



Accepted author version posted online: 08 Mar 2016.



Submit your article to this journal [↗](#)



View related articles [↗](#)



View Crossmark data [↗](#)

Publisher: Taylor & Francis & © 2015 Central Institute for Labour Protection – National Research Institute (CIOP-PIB)

Journal: *International Journal of Occupational Safety and Ergonomics*

DOI: 10.1080/10803548.2016.1156843

Ergonomics Intervention on an Alternative Design of a Spinal Board

Hilma Raimona Zadry*, Lusi Susanti, Dina Rahmayanti

Department of Industrial Engineering, Faculty of Engineering, University of Andalas,
Kampus Limau Manis, Pauh, Padang 25163, West Sumatera, Indonesia

*hilma@ft.unand.ac.id

lusi@ft.unand.ac.id

dina@ft.unand.ac.id

Abstract

A spinal board is the evacuation tool of first aid to help the injured spinal cord. The existing spinal board has several weaknesses, both in terms of user comfort, and the effectiveness and efficiency of the evacuation process. This study designs an ergonomic spinal board using quality function deployment (QFD) approach. A preliminary survey was conducted through direct observation and interviews to volunteers from the Indonesian Red Cross. Data gathered were translated into a questionnaire and answered by 47 participants in West Sumatra. The results indicate that the selection of materials, the application of strap systems, as well as the addition of features are very important in designing an ergonomic spinal board. The data were used in designing an ergonomic spinal board. The use of anthropometric data ensures that this product can accommodate the safety and comfort when immobilized, as well as the flexibility and speed of rescue evacuation process.

Keywords: Spinal board; ergonomics; quality function deployment; product design.

1. Introduction

Indonesia is one of the most disaster prone countries in the world. The country faces multiple hazards such as earthquake, tsunami, volcanic eruption, flood, landslide, drought, and forest fire. Data from the United Nations International Strategy for Disaster Reduction (UN-ISDR) mention that in terms of human exposure or the number of people present in hazard zones that may lose their lives due to a hazard event, Indonesia is the top rank for natural disasters with many people exposed [1]. Moreover, the latest data released by the World Health Organization (WHO) show that Indonesia is the fifth country in the world with the highest number of deaths from traffic accidents. Indonesia also ranks first in the increase of traffic accident numbers by more than 80%. In Indonesia, the death toll from traffic accidents reached 120 people per day (0.02% population) and most of the people who were killed in road accidents were riders of two- or three-wheel vehicles, which is about 61% [2]. Therefore, Indonesia must have a good standard of care to the impact of natural disasters and traffic accidents.

One of injuries common as a result of the disaster and traffic accident is spinal cord injury. Spinal cord injury can result in long-term disability, often with profound effects on the quality of life of the affected individuals and their carers [3]. Injury or damage to the central

nervous system on a larger scale can result in permanent paralysis and death. National Spinal Cord Injury Statistical Centre (NSCISC) collected epidemiological data in the USA from 2010 to 2012 on the cause of injury to the spinal nervous system. The data show that the most common cause of traumatic injury to the spinal nervous system, among others, due to motor vehicle accidents by 36.5%, falls from a height by 28.5%, an intentional act of violence by 14.3%, sports by 9.2%, and other unknown causes by 11.4% [4]. Mortality (risk of death) in victims with traumatic spinal cord injury is estimated at 48% in the first 24 h, and approximately 80% died at the case [5]. This shows that the effective and efficient handling should be done to reduce the risk of injury to the victim's death at times critical. One thing that should be kept in saving lives is the victim first aid and evacuation itself, by knowing the proper technique in moving the victims to a safer area to minimize secondary injury that occurs as a result of the evacuation process itself.

Pre-hospital spinal immobilization is one of the most frequently performed procedures for trauma patients in the field. It aims to stabilize the spine by restricting mobility, thus preventing exacerbation of spinal cord injury during extrication, resuscitation, transport, and evaluation of trauma patients with suspected spinal instability [6]. When spinal injury is suspected, patient extraction and transportation to the hospital must prevent deterioration or damage and ensure protection of the spine. Any equipment used must be light, easy to use and assemble, be to a degree comfortable for the patient and fit securely in the back of the ambulance. In addition, it must also be strong and supportive enough to carry the weight of an adult [7].

In Indonesia, the rigid long spinal board is found in every emergency ambulance and is the primary piece of equipment used to extract, carry and support the patient having spinal injury en route to the hospital. This tool is shaped like an emergency stretcher boards made from wood or polymer with a flat surface that is used to perform the evacuation of the injured spine. The basic principle use of a spinal board is to immobilize (limiting the space) position of the spine so that the injury to the spine due to swing, clash, or shocks that occurred during the evacuation process can be minimized. The important role of the spinal board in the pre-hospital phase is undeniable [7]. This method of immobilization is well established in pre-hospital and in-hospital trauma protocols [8, 9].

However, in practice, the existing spinal board has several shortcomings, both in terms of user comfort and also effectiveness and efficiency of the evacuation process when done. In fact, a previous study found that the use of a spinal board can cause pain, discomfort in victims, and respiratory disorders [10]. Furthermore, a spinal board can decrease tissue perfusion (blockage of the flow of oxygen in the tissue capillaries) at the points given pressure (in this case the placement of ropes or strap), which will lead to the occurrence of decubitus wound, the wound caused by blockage of blood flow on certain body parts [9, 11]. Table 1 shows the methods and results of those studies. The studies claimed that a spinal board has negative effects on human health.

Table 1 is here

There is a large body of research addressing the ergonomic risks associated with patient handling among health care workers, almost all of which has been conducted on nursing personnel [12-15]. There has also been research on the physical demands associated specifically with emergency medical services (EMS) worker job tasks [16-19]. Many studies were also found on the effect of the spinal immobilization devices on the patients' health [6, 11, 20-22]. Some previous research discussed the comparison between a spinal board and other related devices [23-28]. Table 2 shows the results of the comparison.

Table 2 is here

The comparison shows that the spinal board has strengths and weaknesses compared to the other tools. These results can be used as a reference for designing better spinal boards. Moreover, very few researchers have discussed the ergonomics design of pre-hospital management of trauma devices, especially related to the spinal immobilization devices. By observing the facts, it can be concluded that it is necessary to design an alternative spinal board using an ergonomics approach. It aims to achieve mobility and better equipment compatibility when in use so that the evacuation process can be performed more effectively, efficiently and safely. By doing this, it is expected that the risk of death of victims with traumatic injuries to the victim's spine can be minimized, and thus increase the comfort and safety of both victims and rescuers when evacuation is done.

Regarding the methods for designing the new product development, quality function deployment (QFD) is a significant methodological approach to enhance customer satisfaction and reduce the product costs and development cycle time. It is also a crucial tool to increase time and resources saving throughout all stages – design to production planning [29]. QFD has been profitably applied by industries around the world [30-32]. A previous study has been conducted to identify the design requirements of an ergonomic spinal board [33]. Hence, this study used those requirements for designing an ergonomic spinal board.

2. Identification of Design Requirements for an Ergonomic Spinal Board

The identification of design requirements for an ergonomic spinal board has been conducted through a preliminary study by a direct observation of the actual use of the existing spinal board, interviewing and collecting questionnaires from 47 participants from medics, Red Cross, Ambulance Unit Medical Officer and rescue team of Padang, West Sumatera [33]. The interviews were carried out to the volunteers from the Indonesian Red Cross of West Sumatera to know in general how customers respond to the existing spinal board on the market nowadays as well as the characteristics of the customers towards the desired spinal board in the future. The interview results serve as a reference in designing the research questionnaire. It is also a method to get an initial picture of customer expectations for designing an ergonomic spinal board.

The survey questionnaire was developed based on the data from the interviews. It also refers to the dimensions of quality according to Garvin [34] and ergonomics principles from product design [35]. The criteria include performance, features, durability, and aesthetics. It is added by the price aspect as proposed by the American Society for Quality Control (ASQC). The questionnaire aims to investigate the customer requirements and desires related to the ergonomic spinal board.

The collected data of survey questionnaires were processed using QFD design through the House of Quality (HoQ). The HoQ consists of several activities supported by various tables and matrices. The basic idea is to translate customer requirements into the product design requirements in order to increase customer satisfaction [36-38]. The HoQ for the ergonomic spinal board has been developed in a preliminary study [33] using the following steps:

- Determine customer requirements and customer important ratings
- Translate customer requirements into measurable technical requirements
- Determine the relationship between customer requirements and technical requirements
- Determine the interactions between technical requirements

- Determine the priority of technical requirements
- Determine design requirements
- Determine the relationship between technical requirements and design requirements
- Determine the priority of design requirements

Figure 1 and Figure 2 present the HoQ for the ergonomic spinal board.

Figure 1 is here

Figure 2 is here

2. Product Design

The ergonomic spinal board was designed based on the HoQ results in Figure 1 and 2. It was designed based on the required characteristics in functions, appearance, safety and assemblability. Additional features were designed in order to improve the spinal board design. Then, anthropometric data were applied in the process of designing to fit the product with human use. Additional features in this product are listed in the next sections.

2.1. *The spinal board is foldable*

The spinal board has quite large dimensions; this is one of the deficiencies that may reduce its flexibility. Modifying the shape of the main board by dividing it into two folded in the area under the buttocks was the best solution to improve the flexibility.

Figure 3a and 3b are here

2.2. *Head Immobilizer Integrated with the Spinal Board*

Generally, the head immobilizer for a spinal board is a separate device that certainly requires more time to install. Thus in this design, the head immobilizer was integrated directly into the spinal board

Figure 4 is here

2.3. *Strap System*

The system applied in the design straps is an ECS-straps system. It is a crossing restraint system for immobilization, where the safety, determined by the self-adherent strips closure, the sliding of the cross-sectional belts upon the longitudinal one and its extension will allow a better fit to the victim's body. The buckle lock uses a plastic bag buckle located at the centre of the straps. Straps facing the victim's body are equipped with ethylene vinyl acetate (EVA) foam pads to reduce the risk of decubitus sores due to oxygen blockage in the tissue capillaries at the placement of the straps. The straps on the chest can also be used as thongs, thus the spinal board in the folded state can be carried like a backpack.

Figure 5 is here

2.4. Main Board Material

High-density polyethylene (HDPE) was used in designing the main board because of its strength. However, inside of the board, polyurethane was used to reduce the overall weight of the spinal board.

2.5. Anthropometric Data Used

For the ergonomic design of the spinal board, the anthropometric data are a prerequisite. In this research, the product was designed using anthropometric data of the Indonesian population aged 15–64 years. Figure 6 shows the anthropometric dimensions used in the design and Table 3 presents the data.

Figure 6 is here

Table 3 is here

The application of anthropometric data is discussed in the following sections.

2.5.1. Hand-hold slot

The hand-hold slot dimension was design based on the grip diameter, hand breadth and hand thickness dimensions. The 5th percentile value of grip diameter was used as the hand grip size, which is equal to 4.40 cm, while the 95th percentile value of hand breadth (10.20 cm) was used as the handle length. Taking the clearance 4 cm on each side of the grip, the handle length comes to 14.20 cm and this value is recommended for the handle length. The clearance aims to facilitate the user's hand position as well as to provide an area for the strap clips to tie straps on the board. Then, the 95th percentile value of hand thickness was used as the space to insert fingers (slot) on the handle. The value is 4.13 cm after adding 1 cm as the clearance.

2.5.2. Main board length

The main board was designed so that it can be folded into two parts, the top and bottom folds. The length of the top fold was determined based on the dimensions from the top of the head into the fingertip height (the 95th percentile value of stature dimension minus the 95th percentile value of fingertip height = $166.99 \text{ cm} - 62.10 \text{ cm} = 104.89 \text{ cm}$). This percentile was chosen to accommodate an extremely high accident victim. The value was added to the hand grip size (4.40 cm) and the finger slot (4.13 cm). The length of the top fold becomes $104.89 \text{ cm} + 4.40 \text{ cm} + 4.13 \text{ cm} = 113.42 \text{ cm}$.

The length of the bottom fold was determined based on the 95th percentile value of fingertip height (62.10 cm). It was added to the hand grip size (4.40 cm) and the finger slot (4.13 cm). The length of the bottom fold becomes $62.10 \text{ cm} + 4.40 \text{ cm} + 4.13 \text{ cm} = 70.63 \text{ cm}$. Thus, the overall length of the main board was $113.42 \text{ cm} + 70.63 \text{ cm} = 184.05 \text{ cm}$.

2.5.3. Main board width

The main board width of the top fold was determined from the 95th percentile of shoulder breadth (45.51 cm). While the width of the bottom fold was designed tapers at foot end to facilitate the immobilization process and to strengthen the bond straps on the bottom of the victim's body. To that end, the width of the bottom main board was derived from the 95th

percentile value of foot breadth (10.76 cm). It was multiplied by 2 to accommodate the victim's feet ($2 \times 10.76 \text{ cm} = 21.52 \text{ cm}$). Taking the clearance for handle size (hand grip and finger slot) on the right and left sides ($2 \times 8.53 \text{ cm} = 17.06 \text{ cm}$), resulted in the width of the main board at foot end was 38.58 cm ($21.52 \text{ cm} + 17.06 \text{ cm}$).

2.5.4. Head immobilizer size

The head immobilizer length was derived from the difference between the 95th percentile values of stature and shoulder height dimensions ($166.99 \text{ cm} - 127.18 \text{ cm} = 39.81 \text{ cm}$). On the other hand, the width of the head immobilizer was based on the 95th percentile value of head breadth added by 2 cm clearance ($13.70 \text{ cm} + 2 \text{ cm} = 15.70 \text{ cm}$). The head immobilizer was also equipped with foam pads made from EVA with a thickness of each side of 3 cm to accommodate victims with small dimensions.

3. Discussion

Customer important ratings show that the highest requirements in the spinal board design according to the customers are the selection of main board materials, the application of spinal board strap systems, as well as the addition of spinal board features. The variable that gets the highest rating is "The materials can be penetrated by X-rays" with the rating value of 4.36 or classified as "important". This is because the victim should be immobilized well until the scanning process using X-rays is completed. The transfer of the victim without immobilization tool will increase the risk of secondary injury.

Polyethylene and polyurethane are the best options to be used as the main board material because of their ability and endurance. Those materials can also answer the fourth rating "Spinal board material is easy to clean" and the sixth rating "Spinal board material is stainless". This is because polyethylene and polyurethane are thermoplastic materials with small pores so they do not absorb water and can survive at extreme temperatures.

In terms of strength, polyethylene, especially HDPE, has good strength because it has a high density equal to 0.941 g/cm^3 , with an average tensile strength of 32 MPa [39]. It can answer the customer requirement on the seventh rating "Spinal board ability in resisting body weight". Therefore, for the parts which have the important function as weight-bearing on the main board such as the bottom frame, hinges, connecting pegs, and side handles are made using rigid HDPE, while at the top of main board, HDPE is used as outer shell with polyurethane on the inside. Thus it can reduce the overall weight of the spinal board, but will not affect its strength.

The next highest customer requirements are related to the strap system. It includes "The strength of straps to resist body movement", "Spinal board straps are powerful", and "The speed of strap installation". It shows that the selection and application of a strap system, which is strong and has quick installation, are important for the customers. Therefore, the ECS-straps system with nylon will be used to design the straps in the product. ECS-straps are a crossing restraint system for both adults and children and can be used on a variety of transport devices such as boards and vacuum mattresses. The sliding of the cross-sectional belts upon the longitudinal one and its extension will allow a better fit to the victim's body. All these features make ECS-straps an innovative and versatile device for any kind of immobilization operation [40]. This system makes a bond not rely on a single point only, so the risk of rope cut off is smaller. By implementing this system, the emphasis on the body will be split between two segments of the rope so that the risk of blood blockage is also smaller.

In terms of feature development, customers require "Spinal board handles are anti-slip"

with rating value of 4.08; "The main board can be folded so it is easy to carry" with a value of 3.84, and "Head immobilizer is installed permanently on the spinal board" with a value of 3.64. These features are then implemented in the design. To the side grip on the main board, the handles have a circular shape so that rescuers can grasp the board perfectly. The texture on the grip is also made rougher so that the slip risk is smaller when gripped. At the top of the board are also added head immobilizer features integrated on the main board so that the victims' head can be detained without any additional devices so the evacuation process can be faster. The spinal board can be folded into two parts to increase the rescuers' flexibility when carrying it. All components including hinges player in the crease and the head immobilizer are made from the same material as the main board. So it can still be penetrated by X-rays but does not reduce the strength and resilience of the spinal board.

In terms of product design performance, the spinal board was designed to meet consumer needs. The product was modified in the shape and dimensions of the main board, the shape and the application of the strap system, then the addition of some features to support the spinal board. Here is a description of each modification:

- Modifications on the shape and dimensions of the main board

On the main board, modifications were carried out on some parts, such as side grip shape, main board framework, the main board materials, as well as the application of fold on the main board. On the handle side, the diameter of the handle is determined based on anthropometry data. Therefore, the rescuers can grasp the spinal board well and improve the safety of spinal board use. The size of the cavity is also made larger so as to enable rescuers' fingers to be easily inserted under the patient's body. The flexibility is also enhanced by applying the fold hinged in the middle of the board. The fold was made under buttock so that the spinal has been supported by the top of the board.

- Modifications on the strap system

As explained before, the strap system applied to the design is the ECS-straps system. The straps are crossed in three parts of the body: the chest, waist, and legs. For ease of installation, the straps are equipped with a bag buckle. The bag buckle is integrated on one segment of the straps in the middle of the binder that can be adjusted in length according to the needs. The use of a bag buckle also allows rescuers to bring the board in the folded state as using a backpack so that the spinal board would be more practical when being transported. In addition, to increase the patient's comfort the strap in direct contact with the patient's body is given EVA foam pads so the patient's skin will not be scratched.

- Additional features

Additional features implemented in this design are giving texture to the spinal board grip as well as head immobilizer which is integrated directly into the main board. Head immobilizer will certainly save the evacuation time. In addition, the presence of EVA foam pads on the inside of head immobilizer will accommodate the head of the patient with extreme dimensions.

Ergonomics study focused on efforts to achieve a design that meets "fitting the task to the man". Ergonomics studies lead to the benefit of man does not merely lead to the technical or functional aspects of the product. The design of spinal board in this study accommodates two sides' interests of users such as safety and comfort when immobilized, as well as the rescuers, such as flexibility and speed of rescue evacuation process. The use of

anthropometric variables was also adjusted to the dimensions of the Indonesian population, which is expected that this product is really targeted to help efforts in controlling accidents and disasters in Indonesia.

4. Conclusion

This study has succeeded in making an alternative design of spinal board to increase the effectiveness and efficiency of the existing spinal board products. The design was made in accordance with the customer requirements and consultancy to the experts using the QFD method. The results indicate that the selection of spinal board materials, the application of strap systems, as well as the addition of spinal board features are very important to design an ergonomic spinal board. The improvement of product design includes:

- Application of HDPE and polyurethane on the main board.
- Head immobilizer is integrated on the main board.
- The strap system is modified by implementing the ECS-straps system, which is equipped with a bag buckle to increase the speed of installation process.
- Addition of fold under the buttock on the main board.

The next phase will discuss parts deployment until production planning. Thus, the ergonomic spine board can be designed in accordance with the conditions and the latest technology.

Acknowledgment

The author is grateful to the Directorate General for Higher Education of Indonesia for supporting this research under grant Penelitian Unggulan Perguruan Tinggi (PUPT) No. 44/UN.16/UPT/LPPM/2015.

References

1. AIPA. Indonesia's country report on disaster response management. ASEAN Inter-Parliamentary Assembly, 3rd AIPA CAUCUS; 2011, 31 May – 3 June, Manila, Philippines.
2. World Health Organization. Global status report on road safety 2013: supporting a decade of action. summary. 2013.
3. Kwan I, Bunn F, Roberts IG. Spinal immobilisation for trauma patients. The Cochrane Library. London: Wiley; 2009.
4. National Spinal Cord Injury Statistical Center (NSCISC). Spinal cord injury facts and figures at a glance. Birmingham (AL): NSCISC; 2013.
5. Evans T, Brown H. Road traffic crashes: operationalizing equity in the context of health sector reform. *Int J Inj Contr Saf Promot.* 2003; 10(1-2): 11-12.
6. Kwan I, Bunn F. Effects of prehospital spinal immobilization: a systematic review of randomized trials on healthy subjects. *Prehos Disaster Med.* 2005; 20(1): 47-53.
7. Stagg MJ, Lovell ME. A repeat audit of spinal board usage in the emergency department. *Injury.* 2008; 39(3): 323-326.
8. American College of Surgeons Committee on Trauma. Advanced trauma life support for doctors. 7th ed. Chicago (IL): American College of Surgeons; 2004.

9. [no authors listed] EMS spinal precautions and the use of the long backboard. *Prehosp Emerg Care*. 2013; 17(3): 392-393.
10. Chan D, Goldberg R, Tascone A, et al. The effect of spinal immobilization on healthy volunteers. *Ann Emerg Med*. 1994; 23(1): 48-51.
11. Bauer D, Kowalski R. Effect of spinal immobilization devices on pulmonary function in the healthy, nonsmoking man. *Ann Emerg Med*. 1988; 17(9): 915-918.
12. Hignett S. Systematic review of patient handling activities starting in lying, sitting and standing positions. *J Adv Nurs*. 2003; 41: 542-552.
13. Bos EH, Krol B, Van Der Star A, et al. The effects of occupational interventions on reduction of musculoskeletal symptoms in the nursing profession. *Ergonomics*. 2006; 49(7): 706-723.
14. Waters T, Collins J, Galinsky T, et al. NIOSH research efforts to prevent musculoskeletal disorders in the healthcare industry. *Orthop Nurs*. 2006; 25(6): 380-389.
15. Arsalani N, Fallahi-Khoshknab M, Josephson M, et al. Musculoskeletal disorders and working conditions among iranian nursing Personnel. *Int J Occup Saf Ergon*. 2014; 20(4): 671-680.
16. Lavender SA, Conrad KM, Reichelt PA, et al. Designing ergonomic interventions for EMS workers, part I: transporting patients down the stairs. *Appl Ergon*. 2007; 38(1): 71-81.
17. Lavender SA, Conrad KM, Reichelt PA, et al. Designing ergonomic interventions for EMS workers—part II: lateral transfers. *Appl Ergon*. 2007; 38(2): 227-236.
18. Lavender SA, Conrad KM, Reichelt PA, et al. Designing ergonomic interventions for emergency medical services workers—part III: bed to stairchair transfers. *Appl Ergon*. 2007; 38(5): 581-589.
19. Conrad KM, Reichelt PA, Lavender SA, et al. Designing ergonomic interventions for EMS workers: concept generation of patient-handling devices. *Appl Ergon*. 2008; 39(6): 792-802.
20. Hauswald M, Hsu M, Stockoff C. Maximizing comfort and minimizing ischemia: a comparison of four methods of spinal immobilization. *Prehosp Emerg Care*. 2000; 4(3): 250-252.
21. Mok JM, Jackson KL, Fang R, et al. Effect of vacuum spine board immobilization on incidence of pressure ulcers during evacuation of military casualties from theater. *Spine J*. 2013; 13(12): 1801-1808.
22. Oomens CWJ, Zenhorst W, Broek M, et al. A numerical study to analyse the risk for pressure ulcer development on a spine board. *Clin Biomech*. 2013; 28(7): 736-742.
23. Lovell ME, Evans JH. A comparison of the spinal board and the vacuum stretcher, spinal stability and interface pressure. *Injury*. 1994; 25(3): 179-180.
24. Johnson DR, Hauswald M, Stockhoff C. Comparison of a vacuum splint device to a rigid backboard for spinal immobilization. *Am J Emerg Med*. 1996; 14(4): 369-372.
25. Main PW, Lovell ME. A review of seven support surfaces with emphasis on their protection of the spinally injured. *J Accid Emerg Med*. 1996; 13(1): 34-37.
26. Cross DA, Baskerville J. Comparison of perceived pain with different immobilisation techniques. *Prehosp Emerg Care*. 2001; 5: 270-274.
27. Luscombe MD, Williams JL. Comparison of a long spinal board and vacuum mattress for spinal immobilisation. *Emerg Med J*. 2003; 20(5): 476-478.
28. Mahshidfar B, Mofidi M, Yari AR, et al. Long backboard versus vacuum mattress splint to immobilize whole spine in trauma victims in the field: a randomized clinical trial. *Prehosp Disaster Med*. 2013; 28(5): 462-465.
29. Shil NC, Ali MA, Paiker NR. Robust customer satisfaction model using QFD. *Int J Prod Qual Manag*. 2010; 6(1): 112-136.

30. Bergman BKB. Quality from customer needs to customer satisfaction. London: McGraw-Hill; 1994.
31. Geum Y, Kwak R, Park Y. Modularizing services: a modified HoQ approach. *Comput Ind Eng.* 2012; 62(2): 579-590.
32. Vezzetti E, Moos S, Kretli S. A product lifecycle management methodology for supporting knowledge reuse in the consumer packaged goods domain. *Comput Aided Des.* 2011; 43: 1902–1911.
33. Zadry HR, Rahmayanti D, Susanti L, et al. Identification of design requirements for ergonomic long spinal board using Quality Function Deployment (QFD). *Procedia Manufacturing.* 2015; 3: 4673-4680.
34. Garvin DA. *Managing quality: the strategic and competitive edge.* New York: Free Press; 1988.
35. Zhang F, Yang M, Liu W. Using integrated quality function deployment and theory of innovation problem solving approach for ergonomic product design. *Comput Ind Eng.* 2014; 76: 60–74.
36. Marsot J. A methodological tool for integration of ergonomics at the design stage. *Appl Ergon.* 2005; 36(2): 185-192.
37. Lai X, Xie M, Tan KC, et al. Ranking of customer requirements in a competitive environment. *Comput Ind Eng.* 2008; 54: 202–214.
38. Raharjo H, Brombacher AC, Xie M. Dealing with subjectivity in early product design phase: a systematic approach to exploit Quality Function Deployment potentials. *Comput Ind Eng.* 2008; 55: 253–278.
39. Peacock A. *Handbook of polyethylene: structures, properties, and applications.* New York: Dekker; 2000.
40. BCAS_BIOMED, Spineboard straps. <http://www.bcasbiomed.co.uk/products-page/spencer/spineboard-straps/>. 5th April 2015 at 10:07.

Figure Legends:

1. House of quality phase I: the relationship between the customer requirements and the technical requirements
 Note: HDPE = high-density polyethylene; empty = no relationship (0), Δ = weak (1), o = moderate (3), • = strong (9), + = medium positive relationship, ++ = strong positive relationship.
2. House of quality phase II: the relationship between technical requirements and the design requirements
 Note: HDPE = high-density polyethylene; empty = no relationship (0), Δ = weak (1), o = moderate (3), • = strong (9).
3. Fold in spinal board
4. Head immobilizer
5. Spinal board strap system

6. Anthropometric dimensions

Note: 1 = stature, 2 = shoulder height, 3 = fingertip height, 4 = shoulder breadth, 5 = head breadth, 6 = foot breadth, 7 = hand breadth, 8 = hand thickness, 9 = grip diameter.

Table 1. Previous studies about the effect of spinal board on human health

Author	Objective	Method	Result
Kwan and Bunn [6]	To evaluate the effects of spinal immobilization on healthy participants.	A systematic review of randomized, controlled trials of spinal immobilization on healthy participants.	For immobilization efficacy, collars, spinal boards, vacuum splints, and abdominal/torso strapping provided a significant reduction in spinal movement. Adverse effects of spinal immobilization included a significant increase in respiratory effort, skin ischemia, pain, and discomfort.
Chan et al. [10]	To determine the effects of standard spinal immobilization on a group of healthy volunteers with respect to induced pain and discomfort.	<ul style="list-style-type: none"> • Participants were 21 healthy volunteers with no history of back disease. • Subjects were placed in standard backboard immobilization for a 30-minute period. • Number and severity of immediate and delayed symptoms were determined. 	<ul style="list-style-type: none"> • All participants developed pain within the immediate observation period. • Occipital headache and sacral, lumbar, and mandibular pain were the most frequent symptoms.
Bauer et al. [11]	To test the effect of ZED board and spinal board with crisscrossing straps across the thorax on pulmonary function.	<ul style="list-style-type: none"> • Study participants were 15 male volunteers, 23 to 28 years old who had no history of recurrent respiratory disease, heart disease, or current respiratory symptoms and who were non-smokers. • Pulmonary functions were measured with a Breon spirometer. • Measurements included FVC, in one second FEV₁, FEF 25%–75%, and the FEV₁ : FVC ratio. 	Long spinal board and the ZED board used for spinal immobilization have restrictive effects on pulmonary function in the healthy, non-smoking man.

Note:

ZED = Zee Extrication Device, FVC = forced vital capacity, FEV = forced expiratory volume, FEF = forced midexpiratory flow.

Table 2. Comparison between a spinal board and other related devices based on previous studies

Author	Objective	Comparison result	
		Spinal board	Other EMS Devices
Lovell and Evans [23]	To evaluate the differences between the spinal board and the vacuum stretcher in pressure characteristics of these two support surface.	The mean sacral interface pressure on a spinal board (147.3 mmHg) is above average systolic blood pressure (120 mmHg). No support was given to the normal lumbar lordosis by the spinal board.	The mean sacral interface pressure was dramatically reduced with the vacuum stretcher (36 mmHg). Support was given to the normal lumbar lordosis by the vacuum stretcher.
Johnson et al. [24]	To compare a vacuum splint device to a rigid backboard with respect to comfort, speed of application, and degree of immobilization.	The rigid backboard with head block was slightly better at immobilizing the head.	Vacuum splint device was significantly more comfortable, faster to apply and provided better immobilization of the torso and less slippage on a gradual lateral tilt than the rigid backboard.
Main and Lovell [25]	To evaluate seven evacuation suffer support surfaces. These included the conventional spinal board, two designs of vacuum stretcher, a prototype support surface which was a combination of both principles, and three conventional stretchers.	The spinal board has several deficiencies, including lack of support for the lumbar lordosis. It should not be the preferred surface for the transfer of patients with spinal injuries.	The best support surface of those used for spinal protection was the new vacuum stretcher, both for interface pressures and subject comfort. Of the other surfaces, the ambulance stretcher had the best result for comfort and

			interface pressures, although the other stretcher surfaces provided reasonable results and would be safe in the short term.
Cross and Baskerville [26]	To compare the locations and severities of pain generated by a hard wooden spinal board vs. a soft vacuum mattress splint on immobilized volunteers.	The hard spinal board had higher mean pain scores as well as a higher percentage of subjects who reported any pain when compared with the two vacuum mattress splints	
Luscombe and Williams [27]	To compare the stability and comfort afforded by the long spinal board (backboard) and the vacuum mattress.	The mean body movements in the head up position, head down, and lateral tilt were significantly greater on the backboard than on the vacuum mattress ($p < 0.01$ for all planes of movement).	Using the NRS the vacuum mattress was significantly more comfortable than the backboard. In the measured planes the vacuum mattress provides significantly superior stability and comfort than a backboard.
Mahshidfar et al. [28]	To compare spinal immobilization using LBB with a VMS in trauma victims transported by an EMS system.	LBB was easier, faster, and more comfortable for the patient, and provided additional decrease in spinal movement when compared with a VMS.	

Note:

NRS = numerical rating scale, LBB = long backboard, VMS = vacuum mattress splint, EMS = emergency medical services.

Table 3. Anthropometric dimensions of the Indonesian population (in cm)

No.	Dimension	Percentile			SD
		5th	50th	95th	
1	Stature	163.70	165.34	166.99	8.07
2	Shoulder height	123.89	125.54	127.18	19.01
3	Fingertip height	58.81	60.45	62.10	12.76

Ergonomics Intervention

4	Shoulder breadth	42.22	43.86	45.51	7.16
5	Head breadth	10.41	12.05	13.70	3.15
6	Foot breadth	7.47	9.12	10.76	1.80
7	Hand breadth	8.50	9.35	10.20	0.20
8	Hand thickness	2.30	2.68	3.13	0.24
9	Grip diameter (inside)	4.40	4.70	5.00	0.20

Note: Grey indicates percentile used for design.

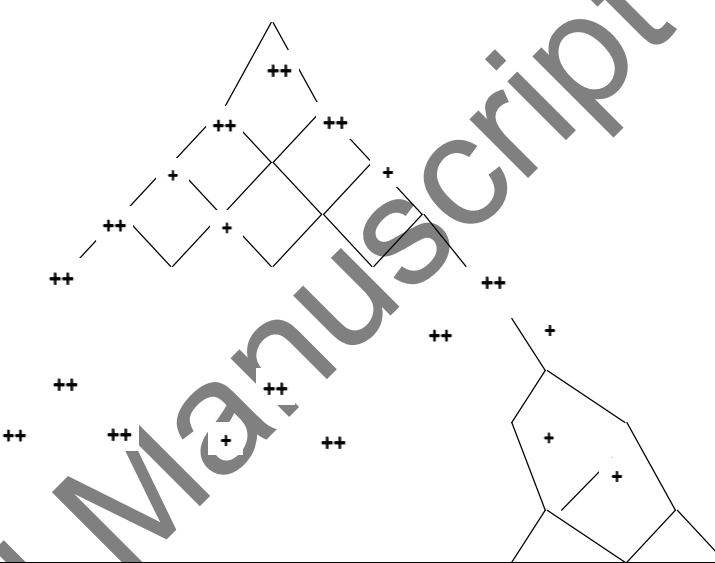

	Technical requirement									
Customer requirement	Customer important rating	Material selection of HDPE and polyurethane as the material for the main board	Material selection of nylon as the material for the straps	Installation mechanism of the straps	Modifications of the straps design	Modifications of the main board design	Extra features on the main board	Colour variations on the design	The handles are textured or coated with rubber	The selection of manufacturing methods
Spinal board ability in resisting body weight	4.10	•	o	o	o	•	Δ		o	•
Spinal board ability in resisting body movement, especially the spine	4.02	•	•	•	•	o	o			o

Ergonomics Intervention

The strength of straps to resist body movement	4.28	o	•	•	•	o				o
The ease of strap installation	3.44	Δ	o	•	•	o	Δ			
The speed of strap installation	4.18	Δ	Δ	•	•	o	Δ			
The comfort during use	3.84			Δ	•	•	•			
The materials can be penetrated by X-rays	4.36	•	•			o	o			o
The main board can be folded so it is easy to carry	3.84	o				•	•			Δ
Fold in the spinal board (if point 1 applies) made under the tail bone so that it is still able to withstand spine movement	3.42	o				•	•			Δ
Straps design can withstand head movement	3.00					•	•			
The main board has a lot of sockets which can be used to install additional devices such as waist and ankle safety	3.42	•		Δ	o	•	•			Δ
Handles are anti-slip	4.08	o		o					•	Δ
Straps are given foam pads to reduce the blockage risk of blood flow	3.46		o	•	•		Δ			Δ
Head immobilizer is installed permanently on the spinal board	3.64	•		o	o	•	•			•

The shape and size of the board do not change evacuation procedures	3.20	0	0	•	•	•	•	•	•	•	•	•	•		
The material is stainless	4.16	•	Δ	Δ									•		
Straps are powerful	4.20	0	•	•	•	•	•	•	•	•	•	•	•		
Straps are not easily broken	3.50	0	•	•	•	•	•	•	•	•	•	•	•		
The material is easy to clean	4.20	•	0	Δ	Δ	Δ	Δ	Δ	Δ	Δ	Δ	Δ	Δ		
The board does not have sharp edges or angles	4.04	•		0	Δ	Δ	0	0	0	0	0	0	•		
There are colour variations	2.86	0	0		Δ	Δ	Δ	Δ	Δ	Δ	Δ	Δ	Δ		
The price is affordable	3.18	•	•	Δ	Δ	Δ	Δ	Δ	Δ	Δ	Δ	Δ	•		
Priority value	411.84	4	283.98	338.90	354.84	399.88	327.06	25.74	56.08	304.64	0.16	0.13	0.01	0.02	0.12
% priority		0.16	0.11	0.14	0.14	0.16	0.13	0.01	0.02	0.12					

Technical requirement	Import rating	The average thickness of HDPE outer layer is 0.50–0.75 cm	•	•	•	•	•	•	•	•	•	•	•	•	•	•	
		The main board, hinges and handles are moulded from solid HDPE without polyurethane injection	•	•	•	•	•	•	•	•	•	•	•	•	•	•	•
		Head immobilizer is moulded from HDPE and polyurethane	•	•	•	•	•	•	•	•	•	•	•	•	•	•	•
		Folds use projection hinge system with a maximum rotation of 180°	•	•	•	•	•	•	•	•	•	•	•	•	•	•	•
		Folds equipped with a locking hinge	•	•	•	•	•	•	•	•	•	•	•	•	•	•	•
		Head immobilizer can be rotated 90° when used	•	•	•	•	•	•	•	•	•	•	•	•	•	•	•
		ECS-strap system used without vertical safety rope and head safety rope	•	•	•	•	•	•	•	•	•	•	•	•	•	•	•
		Lock on the straps is mounted in the middle	•	•	•	•	•	•	•	•	•	•	•	•	•	•	•
		Velcro tape is used as the straps lock on the head immobilizer	•	•	•	•	•	•	•	•	•	•	•	•	•	•	•
		Plastic bag buckle is used as the lock on the ECS straps	•	•	•	•	•	•	•	•	•	•	•	•	•	•	•
		Head immobilizer is fitted with foam pads	•	•	•	•	•	•	•	•	•	•	•	•	•	•	•
		The main board equipped with socket on the bottom of locomotor	•	•	•	•	•	•	•	•	•	•	•	•	•	•	•
		The main board is made using injection molding process	•	•	•	•	•	•	•	•	•	•	•	•	•	•	•
		Mounting hinge uses screw system	•	•	•	•	•	•	•	•	•	•	•	•	•	•	•
		Nylon webbing is used with 4cm width and 0.25cm thickness Rough and rubber textures are applied on the grip of the main board	•	•	•	•	•	•	•	•	•	•	•	•	•	•	•
Color variations on the main board	•	•	•	•	•	•	•	•	•	•	•	•	•	•	•		
Color variations on the strap systems	•	•	•	•	•	•	•	•	•	•	•	•	•	•	•		

Ergonomics Intervention

selecti on of HDPE and polyur ethan e as the materi al for the main board																			
Modifi cation s of the main board design	399. 88	•	•	•	•	•	•	o	Δ	o	o	•	•	•	o		o	•	
Modifi cation s of the straps design	354. 84						o	•	•	•	•		Δ			•			•
Install ation mech anism of the straps	338. 9							•	•	•	•		Δ			•			•
Extra featur es on the main board	327. 06	•	Δ	•	•	•	•	•	o	•	o	•	•	•	o	o	•	•	o
Materi al selecti on of nylon as the materi al for the straps	304. 64							•	•	•	•					•			•
The selecti on of manuf acturi ng metho ds	283. 98	•	•	•	o	o		Δ	Δ	o	o		Δ	•	•	o		Δ	
The handl es are textur ed or coate d with rubber	56.0 8		Δ														•		
Colour variati ons	25.7 4	Δ	Δ	Δ			Δ	o	Δ	Δ	Δ	Δ		•		o	o	•	•

Ergonomics Intervention

on the design																			
Priority value	12831	10270	12831	11101	11101	8868	13490	10676	14418	12044	7804	8756	13037	5972	10896	4725	8294	10198	
% priority	0.07	0.05	0.07	0.06	0.06	0.05	0.07	0.06	0.08	0.06	0.04	0.05	0.07	0.03	0.06	0.03	0.04	0.05	

A

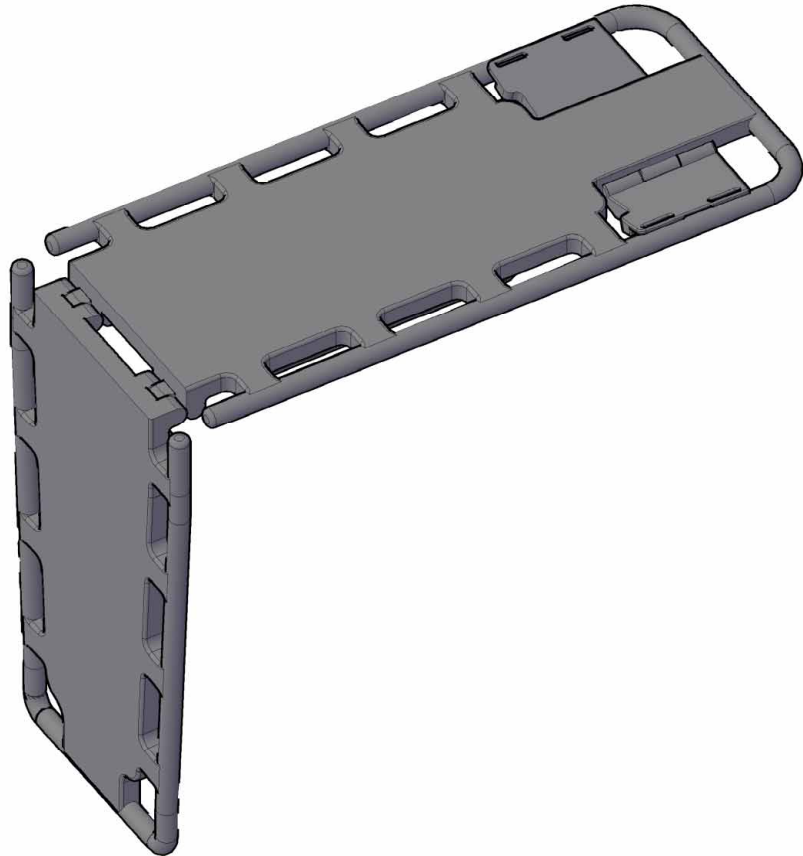

Script



Accepted Manuscript

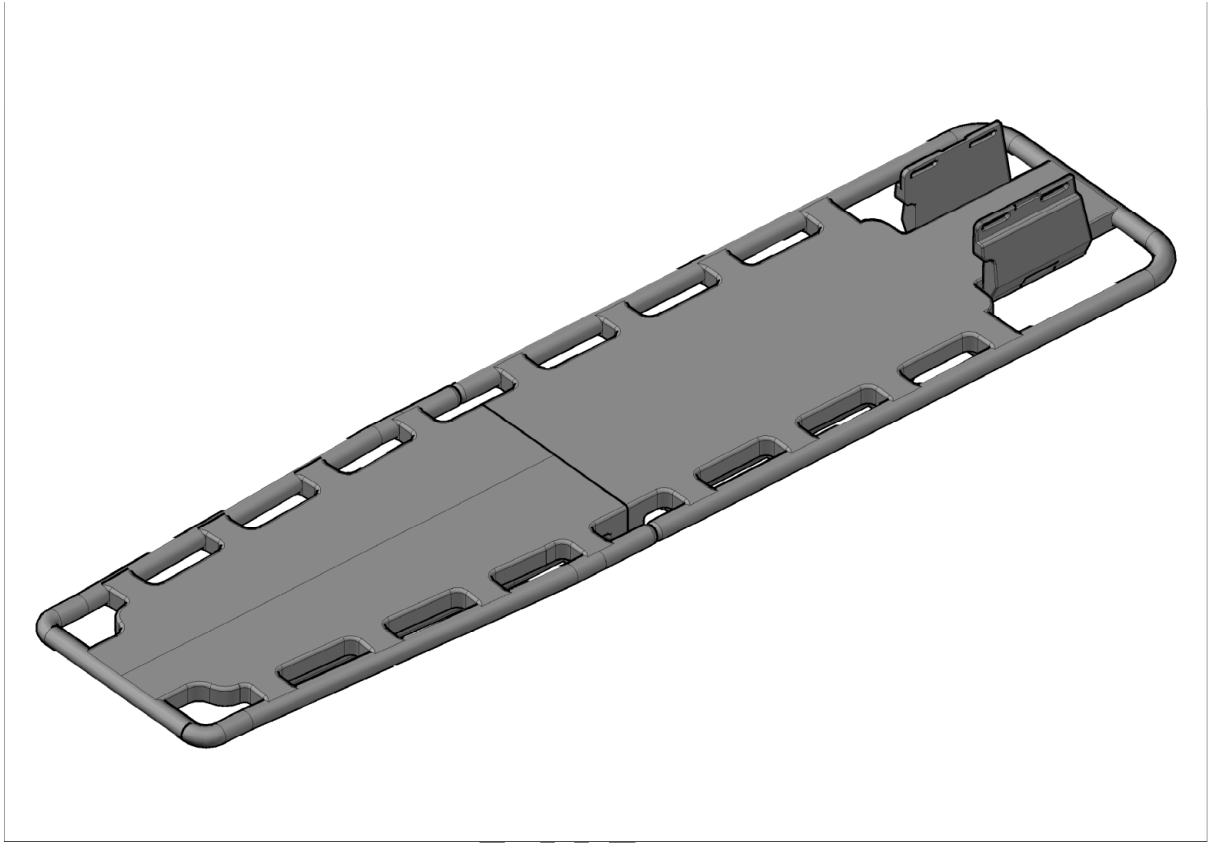

Accepted Manuscript

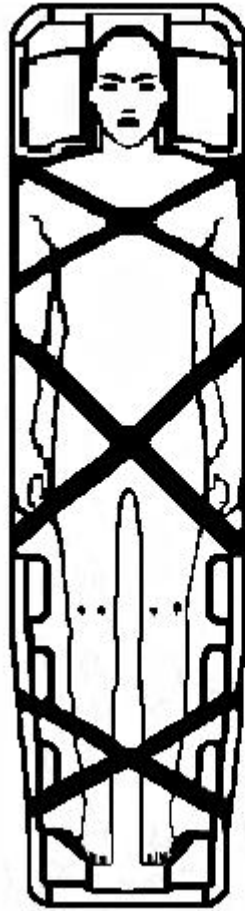

Accepted

191

Ergonomics Intervention

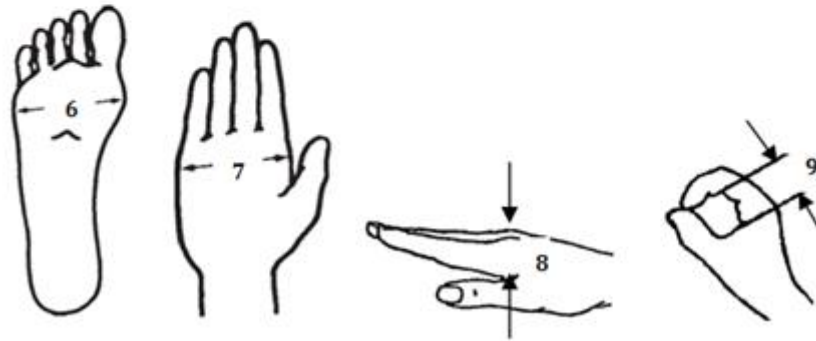
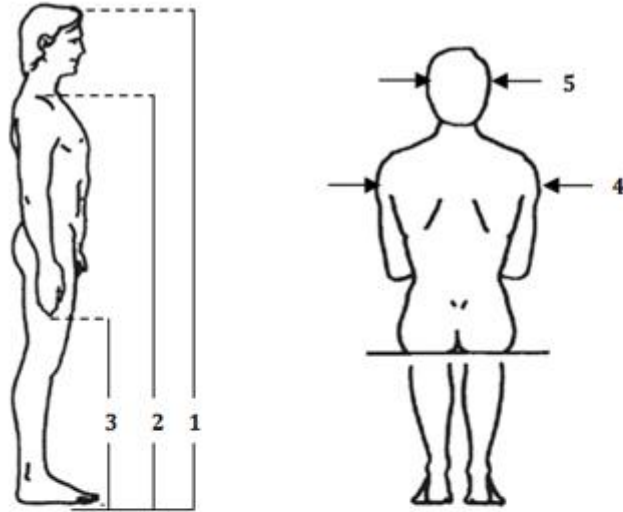

Accepted