

# 12

*by* 12 12

---

**Submission date:** 16-Jul-2020 01:15PM (UTC+0800)

**Submission ID:** 1358111267

**File name:** 4.12\_IOP\_Yendri\_2020\_IOP.pdf (651.5K)

**Word count:** 4810

**Character count:** 23584

PAPER • OPEN ACCESS

## Designing Hygienic and Energy Saving of Water Dispenser Machine

4  
To cite this article: Dodon Yendri *et al* 2020 *IOP Conf. Ser.: Mater. Sci. Eng.* **846** 012039

View the [article online](#) for updates and enhancements.

## Designing Hygienic and Energy Saving of Water Dispenser Machine

<sup>2</sup> Dodon Yendri<sup>1\*</sup>, Hadzimah Rizza<sup>2</sup>, Budi Rahmadya<sup>3</sup>, Derisma<sup>4</sup>

<sup>1,2,3,4</sup> Computer System Department, Faculty of Information Technology, Universitas Andalas, Padang, 25231, Indonesia

Email: dodon@fti.unand.ac.id

**Abstract.** The use of a dispenser at the office is not as frequent as at home, because it is only used during working hours or at certain times. The use of dispensers must be in accordance with established health standards, so the quality of water produced by the dispensers must also be hygienic and free of germs or bacteria. Generally, water dispensers are operated for 24 hours, meaning that the dispensers use up a lot of electrical energy. In addition, the use of dispensers must also comply with established health standards, so the quality of the water produced by the dispensers must also be hygienic and free of germs or bacteria. Meanwhile the quality of the water produced by the device cannot be monitored. To overcome this problem, a study was conducted by designing a hygienic and energy efficient water dispenser design by applying a forward scheduling approach. The design is carried out through several components, namely ultraviolet (UV), dispenser heaters, Arduino Uno sensors, DS18B20 sensors, HC SR-04 sensors, DC pumps, 2 relays, and RTCDS1307. The results of this study indicate that the dispenser heating system can work based on a set schedule by applying an advanced scheduling approach referring to the RTC DS1307 time reading. The UV lamp can be lit for 10 minutes to sterilize the main container of the dispenser with an estimated suppression of E. Coli bacteria about 87.5 colonies / minute. This system is able to suppress the growth of bacteria about 875 colonies for once lighting. This system can control the quality of water that is safe for consumption and saves electricity energy up to 79.87 kWh per month.

### 1. Introduction

In line with the development of technology, automation of electronic equipment has become a demand for users. One of them is the provision of drinking water using a dispenser. Dispenser is widely used in households and offices now because it is more practical for getting hot and cold water. A dispenser is supported by components like heat component for heating dan cool component for cooling. The heater component requires more energy than the cooling one. A dispenser absorbs 330-450 watts of power for heating components and 60-80 watts for cooling components.

The dispenser is equipped with a switch to activate and deactivate the heater, but in practice this switch is often ignored so the heater continues to work all day. This is a waste of energy. Another side, many dispensers in general do not have a system to suppress bacterial growth and also there are not periodic cleaning of the container. It makes bacteria grow unnoticed. There are eight types of bacteria develop in the dispenser container [1].

<sup>3</sup> Content from this work may be used under the terms of the [Creative Commons Attribution 3.0 licence](https://creativecommons.org/licenses/by/4.0/). Any further distribution of this work must maintain attribution to the author(s) and the title of the work, journal citation and DOI.

Published under licence by IOP Publishing Ltd

9 The quality of the water dispenser must be hygienic. Parameters of hygienic is if the water have total coliforms and Escherichia Coli (E. Coli) with units / 10s of colony forming units in 100 ml water samples and the maximum content is 0 [2]. The decree of the Minister of Health of the Republic of Indonesia No. 715 of 2003 regulates the requirements for tableware containers, where a container is hygienic if the number of bacteria does not exceed 100 colonies / cm<sup>2</sup>.

Research on dispenser operation has been carried out by researchers before using the fuzzy method [3]. The results of the study can heat the water temperature with a success percentage of 89%. But in its use the research has not been able to save energy because the heating system stays on all day. The next study [4], to maintain the quality of drinking water can be done by the disinfection process by providing ultraviolet (UV) radiation in the main container. The results showed that ultraviolet rays were able to kill E. coli bacteria in drinking water. Furthermore, ultraviolet disinfection for 10 minutes can reduce the bacteria as much as 875 colonies [5].

Based on the research above, the writer combines research by designing energy-efficient and hygienic dispenser heating systems using the scheduling method. The scheduling method is used to set the active or non-active heater scheduling based on the DS18B20 sensor temperature reading. To ensure the quality of water, a disinfection process is carried out by providing ultraviolet (UV) radiation to the container while to save energy, a relay is used for circuit breakers and time readers use RTCDS1307.

Some studies related to the use of ultraviolet radiation disinfection include purification of drinking water [6], evaluation of the application and contribution of ultraviolet germ irradiation relative to air disinfection [7], efficiency of ultraviolet radiation in reducing cell counts of *Staphylococcus aureus* ATCC 25923 and *Escherichia coli* K-12 [8], increasing the process of water disinfection with ultraviolet [9], investigating the effectiveness of ultraviolet light for disinfection of wastewater [10], evaluating the effects of ultraviolet disinfection on water quality [11].

## 2. Methodology

Basically this research is carried out with a methodology based on the reading time of the RTCDS1307 system which is arranged using the scheduling method as shown in the following Figure 1.

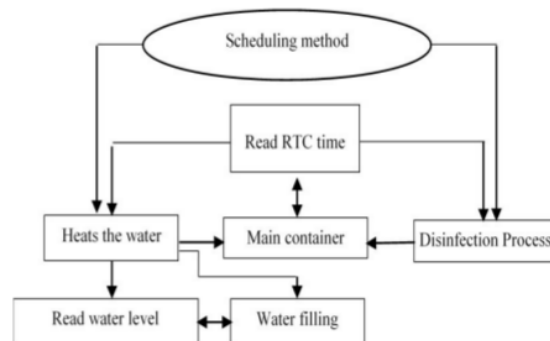

Figure 1. Methodology

The operation of the system is regulated at a schedule of 8:15 a.m. to 8:25 a.m. for disinfection or cleaning, from 10:00 to 11:00 a.m., 00:00-13:00 and 15:00-16:00 for heating water. The first time the system is activated, the system will read the RTCDS1307 time. If the time is read according to the scheduling time for example at 8:15 a.m. the system will activate the main disinfection or cleaning function until 8:25 by activating the UV lamp. If the RTCDS1307 time has passed the 8:25 mark, the system will standby until 09:59. Furthermore, when the RTCDS1307 time enters 10:00 a.m. the system will carry out the function of the heating system until 11:00 a.m., and likewise at 12-13.00 and 15:00-16:00. To accommodate and heat water, electric pot is used which is equipped with a heater.

This energy-efficient and hygienic dispenser heating system research is carried out by blocking the design process in Figure 2.

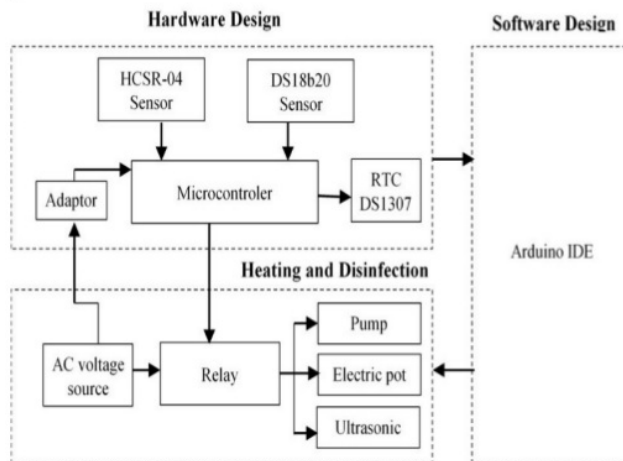

Figure 2. Block design process system

From Figure 2, it can be explained that the design of energy-efficient and hygienic dispenser heating systems consists of three main activities which are hardware design, software design and heating disinfection.

### 3. System Design

#### 3.1 Hardware Design and Parametric Stud

The design of hardware consists of heating components (electric pots and heaters) which are used as storage containers and heating water as an object whose operation schedule will be set, ultraviolet (UV) lights [11],[12],[13] for disinfection in containers main reservoir, DS18B20 sensor [14],[15] to measure temperature, sensor HC SR-04 [16],[14] to read the water level in a heating tank, dc pump as a valve to control the flow of water from the main container to a heating tank with a capacity of 1.6 liter. Relay 1 to activate and deactivate the system according to the instructions of the microcontroller, RTCDS1307 [16] as a system time reader and Arduino Uno as the control center that will process the sensor reading data. Relay 2 for regulating UV lights, pumps and heaters. Energy-efficient and hygienic dispenser heating system hardware designs can be seen in Figure 3.

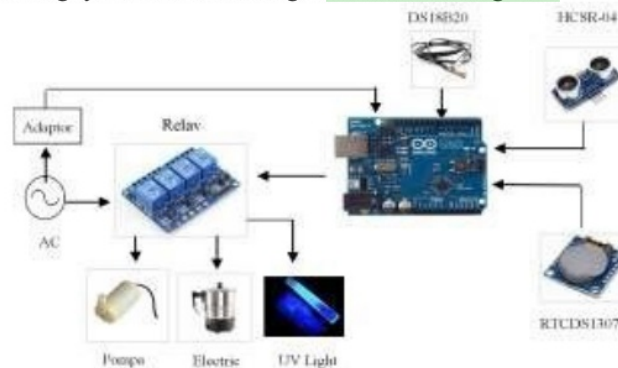

Figure 3. The design of the hardware system

### 3.2 Software Design

The software designing was conducted for the hardware to work in accordance with its functions to activate the built hardware components, The software application using C programming through Arduino IDE for running system. In this system, a scheduling method was used during the operation to acquire the hygiene and energy saving heating system of the dispenser. The scheduling method using forward scheduling approach is shown in Figure 4.

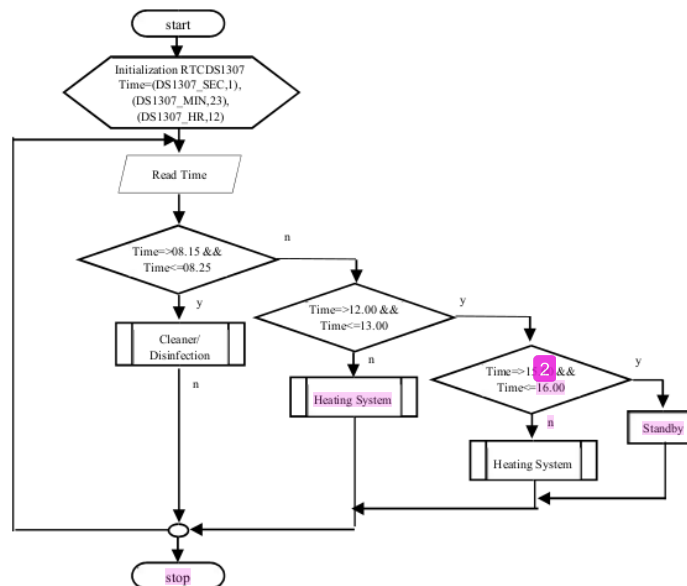

Figure 4. System flowchart of dispenser heating

The value of the RTCDS1307 sensor is reading by the system and adjusted to the predetermined schedule in reference to the scheduling method, namely during 08.15-08.25 where the system conducts “disinfection” process, the system runs the function of “water heating” during 10.00-11.00, 12.00-13.00, and 15.00-16.00. If the time read by the RTCDS1307 sensor is currently not in those time limits, then, the system will go off (standby). In that order, the current will not flow on the system and will surely save energy during the operation.

### 3.3 Process Design

#### 3.3.1 Cleaner/Disinfection

The disinfection process is performed daily by activating the UV light for 10 minutes from 08.15-08.25 with an assumption that during this time, the employees have just started their activities, thus, none of them requires hot water. After the disinfection process is conducted, the UV light is switched off and the system is back on standby for the next schedules.

#### 3.3.2 The Process of Water Filling and Dispenser Heating

The filling and heating of the dispenser are initiated by reading RTCDS1307's time and detecting temperature through the DS18B20 temperature sensor. If the time on RTC DS1307 has been in accordance with the scheduling system (10.00-11.00, 12.00-13.00 and 15.00-16.00), the HCSR-04 sensor will be activated to measure the distance of water height inside the electric pot by reading the floating object which has been re-established. If the reading distance between the floating object and

HCSR-04 sensor is valued as low or equal to 6 cm, then, the water container is determined as full and the water flowing will be stopped, on the contrary, if the reading distance is higher or equal to 10 cm, then, the container is determined as empty and the pump will be activated by flowing the water to fill the electric pot.

The first water heating is performed when the container has been determined as full (the reading distance of HCSR-04 sensor is 6 cm) and low temperature or equal 42°C, then, the heating system will be activated until the temperature reaches its maximum limit (90°C) or before the end of the schedule. If the schedule has not over, thus, the system will be standby for the next change of temperature. The heater will be active again when the temperature is at 86°C. However, if the schedule has ended, thus, the automatic heating system will shut down and the system will go off.

#### 4. Result and Discussions

##### 4.1 The Implementation of Hardware

This system was built with several components, namely the main container which consists of UV light and DC pump placed on the upper part of toolbox, DS18B20 temperature sensor installed on the electric pot equipped with a heater and functioned as the heating component, HCSR-04 ultrasonic sensor installed on middle part of tool box's ceiling right across the surface of floating object installed on the electric pot. While Arduino UNO, RTCDS1307 sensor, relay 1, and relay 2, as well as other components, were arranged on the lowest bottom of the plywood-based dispenser boxes with 40 cm x 60 cm x 20 cm dimension, such as seen in Figure 5.



Figure 5. Overall dispenser heating system

##### 4.2 Implementation

The software in this system was using the Arduino IDE. The programming was performed to read the components and implement the scheduling method for the water heating process. The scheduling method was used through the application of a backward scheduling approach on the operation of dispenser's heater and UV light in accordance with the pre-determined schedule.

##### 4.3 Testing

###### 4.3.1 The UV Light testing

This testing was performed to ensure whether the UV light could light up based on the schedule of the scheduling method. This testing was functioned as the sterilization of the main container on the

dispenser for 10 minutes. The result of UV light's testing for 5 days from October 25th to 29th 2018 is shown in Table 1.

**Table 1.** The testing of UV Light

No	Date	Time on RTC	Condition of UV Light
1	10/05/2018	08.15-08.25	ON
2	10/06/2018	08.15-08.25	ON
3	10/27/2018	08.15-08.25	ON
4	10/28/2018	08.15-08.25	ON
5	10/29/2018	08.15-08.25	ON

From the results of the tests in table 1 above, it can be seen that the UV lights can be lit well and successfully operate according to the given schedule and the predetermined duration of time is 10 minutes every day. So based on the results of the study [6] that the UV light is turned on for 10 minutes. This means that the system can suppress bacteria as much as  $87.5 \times 10 = 875$  colonies.

#### 4.3.2 The DS18B20 Temperature Sensor Testing

This testing was used to discover the temperature read by the sensor (in °C unit) by taking the data every five minutes and then the result was compared to the analog thermometer. Comparison of temperature testing results with DS18B20 sensor and analog thermometer can be seen in Table 2.

**Table 2.** Comparison of temperature testing with DS18B20 sensor and analog thermometer

No	Time	DS18b20 sensor (°C)	Analog Thermometer (°C)	Difference
1	22:00	24.75	25.41	0.66
2	22:05	43.88	44.63	0.75
3	22:10	65.75	66.37	0.62
4	22:15	87.25	88.24	0.99
5	22:16	90.03	90.55	0.52

Based on Table 2, it seen that the temperature measurement results by using a DS18B20 sensor are almost similar to the analog thermometer. There is only very little difference between the two measurements. The difference was due to the specification and accuracy of DS18B20 sensor which amounted to  $\pm 0.5^\circ\text{C}$  to  $-10^\circ\text{C}$ , and  $-10^\circ\text{C}$  to  $+85^\circ\text{C}$ . However, in general, the reading of the DS18B20 temperature sensor was categorized as good with a small difference.

#### 4.3.3 The Heater testing

This testing was performed to test the capability of the tool in heating the water inside the electric pot. The energy used by heater was 350 watt. The testing was begun by heating the water in the heater along with the heater of the conventional dispenser which commonly used by the community with the same energy. Firstly, both tanks filled with 1 liter of water volume respectively, then the 1-hour change of temperature was observed (from 10.00 to 11.00) with the temperature set from  $42^\circ\text{C}$  until it reaches set point ( $90^\circ\text{C}$ ) based on the timing of both heaters. The testing results of both heating systems can be seen in Table 3 as follows.



**Table 3.** The testing of temperature change time and heater status

Time	Heating with the conventional			Heating with the experiment dispenser		
	Temperature	Status	Time (Minute)	Temperature	Status	Time (Minute)
10.00	42°C	ON		42°C	ON	
10.07	68°C	OFF	7			
10.12	63°C	ON				
10.13				90°C	OFF	13
10.14	69°C	OFF	2			
10.28	64°C	ON				
10.30	71°C	OFF	2			
10.31				86°C	ON	
10.33				90°C	OFF	2
10.43	62°C	ON				
10.45	78°C	OFF	2			
10.51				86°C	ON	
10.53	70°C	ON		90°C	OFF	2
10.55	77°C	OFF	2			
11.00	73°C	OFF		88°C	OFF	
Total Heating Time			15	17		

Based on Table 2, it also seen that the cycle of water heating in the conventional dispenser is the difference with the experiment dispenser. In 1 hour (from 10.00-11.00), the conventional dispenser was turning on or active for five times with 15 minutes of total time and 7 minutes of maximum time, namely during the first activation which started from 42oC up to 68oC. While on the experiment dispenser, in an hour operation, the heater was turned on for three times with 17 minutes as the total active time and 13 minutes as the longest active time during the first activation with 42oC as the initial temperature until the 90oC of maximum temperature was achieved.

Seen from the heat resistance, the conventional dispenser was having a big difference with the experiment dispenser. On the conventional dispenser, the decrease of temperature was 5oC (from 68oC to 63oC) which occurred for four minutes (from 10.07-10.12) while on the experiment dispenser, the decrease of temperature was 4oC (from 90oC to 86oC) which occurred for 17 minutes (from 10.14-10.31). The same condition happened on the next temperature decrease from 69oC to 65oC which occurred for 15 minutes (from 10.14-10.28), while on the experiment dispenser, the temperature decreased from 90oC to 86oC which occurred for 17 minutes (from 10.34-10.51). The difference of these changes was caused by the different set point which determined for both dispensers. On the conventional dispenser, the highest temperature was set at +/- 68°C and the lowest temperature was set at +/- 60°C. While the lowest temperature on experiment dispenser was set at 86oC and the highest temperature was set at 90oC. In addition, the material and the impermeability of the heater tank also affect the temperature resistance. From the testing, it can be seen that the heater of experiment dispenser was better compared to the conventional dispenser.

#### 4.4 System Testing and Analysis

##### 4.4.1 The Testing and Analysis of Disinfection Process

The disinfection process in the system is done by irradiating the main container using a UV lamp for 10 minutes. The test results in table 1 show that UV lights are always on for 10 minutes every day for five days. Based on previous research [11], irradiation of UV lamps can suppress bacterial colonies by 87.5 per minute. Thus, every 10 minutes of irradiation every day can suppress bacterial colonies of  $87.5 \times 10 = 875$  colonies every disinfection.

#### 4.4.2 The System Testing and Analysis Based on the Scheduling

The schedule of the system operation was set at 08.15-08.25, 10.00-11.00, 12.00-13.00 and 15.00-16.00. The system testing which based on the scheduling was aimed to ensure that the disinfection process and heating system could control the filling and heating the water on the heater tank in accordance with the pre-determined schedules in which the average operating time in a day was  $\pm 45.5$  minutes to acquire the set point value of temperature ( $90^{\circ}\text{C}$ ) while it took  $\pm 10.08$  minutes of average time for operating the conventional dispenser.

#### 4.4.3 The Analysis of Scheduling Based on Backward Scheduling Approach

The analysis of scheduling based on a backward scheduling approach was initiated by setting a schedule of which a required activity has to be finished, then counting backward to determine the proper time for the first time the activity begins. The implementation of backward scheduling is assuming that the finished date is known and the start date is desired. The disinfection process has to be done by 08.25 with a length of 10 minutes, therefore, it has to be started from 08.15 with an assumption that the employees are already in the office. In similar to the first heating process (10.00-11.00). Employees who yet to have their coffee or tea at their homes will be able to have it after the water is heated. Then, the second heating is adjusted to the break and lunchtime which is around 12.00-13.00. In that order, the filling and heating of water in the dispenser have to be conducted. While the third heating is performed before the employees go home namely at 15.00-16.00, thus, the hot water in the dispenser has already available, in that order, the employees who want to make coffee or tea before coming home are able to do so.

#### 4.5 The Measurement Analysis of Energy Use

After the overall testing of the system can run properly, then, the analysis and measurement of energy use on experiment dispenser were performed which followed by comparing them with the energy measurement of the conventional dispenser. The analysis of the energy measurement of both dispensers can be seen in Table 4 as follows.

**Table 4.** The analysis of energy measurement

Experiment dispenser	Conventional Dispenser
a. The energy used in kW = $\text{kW} = 350 / 1000 = 0.35$ kWh	a. The energy used in kW = $350 / 1000 = 0.35$ kWh
b. Total usage time in a day = 45.5 minutes (0.75 hour), kWh = $0.35 \times 0.75 = 0.256$ kWh/day	b. Total operation time of heater in the first hour = 17 minutes = 0.28 hour
c. Arduino's Energy = $0.0005 \times 24 = 0.012$ kWh/day	c. Total operation time of heater for the next 1 hour = 8.5 minutes = 0.14 hour
d. UV Light's Energy = $0.005 \times 0.16 = 0.0008$ kWh/day	d. Total usage in a day = $(0.28 + 0.14) \times 24$ hours = 10.08 hour
e. Pump Energy = $0.0015 \times 0.016 = 0.000024$ kWh/day	e. Total monthly energy usage = $10.08 \times 0.35 \times 24$ days = 84.67 kWh
f. Total in 1 day = $0.256 + 0.012 + 0.0008 + 0.000024 = 0.20$ kWh/day	
g. Total monthly energy usage: kWh in 1 day $\times 24$ days = $0.20 \text{ kWh} \times 24 = 4.8$ kWh	

According to the measurement results in Table 3, it can be seen that the energy usages of both dispensers are very much different. The experiment dispenser consumed 4.8 kWh/month energy while the conventional dispenser consumed 84.67 kWh/month. It means that the experiment dispenser can save 79.87 kWh energy per month. This significant difference was due to the testing of the conventional dispenser which required 17 minutes of time for heating in the first hour and 8.5 minutes for the following hours or equal to 3 hours 53 minutes in a day. In addition, the conventional dispenser was active for 24 hours while for the experiment dispenser, total heater operation in a day was 45.5 minutes on average.

## 5. Conclusion

There are several conclusions is taken which described as follows:

1. The heating system of the experiment dispenser could work in accordance with the scheduling based on the backward scheduling approach which has been determined in reference to the time reading of RTC DS1307.
2. The UV light could active to perform 10 minutes-disinfection on the main container of the dispenser with an estimation of bacteria suppression amounted to 87.5 colonies/minute and 875 colonies for 1 radiation time.
3. The heating system of the dispenser through the application of forwarding scheduling method could save the energy usage up to 79.87 kWh per month.

## Acknowledgement

This research was performed to see into what extent the experiment dispenser can produce hygienic water quality and save energy during the usage of electrical power compared to the conventional dispenser which commonly used in the community. In this research, the author has received massive support from colleagues in providing ideas and recommendations for the success of the research. Due to that matter, the author would like to thank Hadzimah Rizza, Budi Rahmadya, and Derisma as well as other friends who cannot be mentioned individually. Special gratitude toward the rector of Andalas University who has given an opportunity for the author to publish this paper.

## References

- [1] Hed Series Peltier-Type Temperature Control System for Chemical Liquids, Chemical Thermo-con *SMC Corp. Am.* 356–72
- [2] Permenkes R 2017 Peraturan Menteri Kesehatan Republik Indonesia Nomor 32 Tahun 2017 Tentang Standar Baku Mutu Kesehatan Lingkungan Dan Persyaratan Kesehatan Air Untuk Keperluan Higiene Sanitasi, Kolam Renang, Solus Per Aqua dan Pemandian Umum *Peratur. Menteri Kesehat. Republik Indones.* 17–20
- [3] Baumgartner A and Grand M 2006 Bacteriological quality of drinking water from dispensers (coolers) and possible control measures *J. Food Prot.* **69** 3043–6
- [4] Wandrivel R, Suharti N and Lestari Y 2012 Kualitas Air Minum Yang Diproduksi Depot Air Minum Isi Ulang Di Kecamatan Bungus Padang Berdasarkan Persyaratan Mikrobiologi *J. Kesehat. Andalas* **1** 129–33
- [5] A. S, As Z A and Setiadi G 2014 Efektivitas “Portable UV Disinfection” dalam Menurunkan Angka Bakteri (*Escherichia Coli Spp*) pada Air Minum *J. Kesehat. Lingkung. J. dan Apl. Tek. Kesehat. Lingkung.* **11** 223
- [6] Johnson K M, Anil Kumar M R, Ponmurugan P and Gananamangai B M 2010 Ultraviolet Radiation and Its Germicidal Effect in Drinking Water Purification *J. Phytol.* **2010** 12–9
- [7] Memarzadeh F, Olmsted R N and Bartley J M 2010 Applications of ultraviolet germicidal irradiation disinfection in health care facilities: Effective adjunct, but not stand-alone technology *Am. J. Infect. Control* **38** S13–24
- [8] De Sá Silva C A, De Andrade N J, Soares N D F F and Ferreira S O 2003 Evaluation of ultraviolet radiation to control microorganisms adhering to low-density polyethylene films *Brazilian J. Microbiol.* **34** 175–8
- [9] Said M B E N and Otaki M 2013 Enhancement of ultraviolet water disinfection process *African J. Biotechnol.* **12** 2932–8
- [10] Oparaku N F, Mgbenka B O and Ibeto C N 2011 Waste Water Disinfection Utilizing Ultraviolet Light *J. Environ. Technol.* **4** 73–8
- [11] Choi Y and Choi Y June 2010 The effects of UV disinfection on drinking water quality in distribution systems *Water Res.* **44** 115–22
- [12] Mofidi A A, Rochelle P A, Chou C I, Mehta H M, Verne L and Linden K G 2002 Bacterial

Survival After Ultraviolet Light Disinfection : Resistance , Regrowth and Repair *Am. Water Work. Assoc. Annu. Conf. Exhib.* 1–11

- [13] Charnas C L, Bell K Y, Adams D, Chambers J, Cohrs D, Hammer D and Schmidt P 2012 Wastewater UV Disinfection Systems– Lessons Learned During Performance Testing *IUVA News* **14** 14–9
- [14] Nie S, Cheng Y and Dai Y 2013 Characteristic Analysis of DS18B20 Temperature Sensor in the High-voltage Transmission Lines' Dynamic Capacity Increase *Energy Power Eng.* **05** 557–60
- [15] Fezari M and Al Dahoud A 2019 Exploring One-wire Temperature sensor “DS18B20” with Microcontrollers *Univ. Al-Zaytoonah Fac. IT* 1–9
- [16] Sidam P, Mate M, Nagarare P, Katle S, Dhapodkar S and Nasare R 2018 IOT Based Smart Garbage Bin Alert System using HC-SR04 Ultrasonic Sensor *Int. J. Innov. Sci. Res. Technol.* **3** 277–80

## ORIGINALITY REPORT

12%

SIMILARITY INDEX

7%

INTERNET SOURCES

5%

PUBLICATIONS

11%

STUDENT PAPERS

## PRIMARY SOURCES

1

[repository.uin-malang.ac.id](http://repository.uin-malang.ac.id)

Internet Source

3%

2

Submitted to Universitas Andalas

Student Paper

3%

3

[repository.nwu.ac.za](http://repository.nwu.ac.za)

Internet Source

1%

4

[umpir.ump.edu.my](http://umpir.ump.edu.my)

Internet Source

1%

5

Submitted to University of Leeds

Student Paper

&lt;1%

6

[pureapps2.hw.ac.uk](http://pureapps2.hw.ac.uk)

Internet Source

&lt;1%

7

[onlinelibrary.wiley.com](http://onlinelibrary.wiley.com)

Internet Source

&lt;1%

8

[www.oalib.com](http://www.oalib.com)

Internet Source

&lt;1%

9

Submitted to Ngee Ann Polytechnic

Student Paper

&lt;1%

10	<a href="http://journal.poltekkes-mks.ac.id">journal.poltekkes-mks.ac.id</a> Internet Source	<1%
11	Submitted to Universitas Riau Student Paper	<1%
12	"Proceeding of The 4th International Seminar on Linguistics (ISOL-4)", Walter de Gruyter GmbH, 2019 Publication	<1%
13	<a href="http://hdl.handle.net">hdl.handle.net</a> Internet Source	<1%
14	Submitted to Caledonian College of Engineering Student Paper	<1%
15	<a href="http://ejournal.kesling-poltekkesbjm.com">ejournal.kesling-poltekkesbjm.com</a> Internet Source	<1%
16	Submitted to University of Greenwich Student Paper	<1%

Exclude quotes      On

Exclude matches      Off

Exclude bibliography      On