



Ergonomics intervention on an alternative design of a spinal board

Hilma Raimona Zadry, Lusi Susanti & Dina Rahmayanti

To cite this article: Hilma Raimona Zadry, Lusi Susanti & Dina Rahmayanti (2016): Ergonomics intervention on an alternative design of a spinal board, International Journal of Occupational Safety and Ergonomics, DOI: [10.1080/10803548.2016.1156843](https://doi.org/10.1080/10803548.2016.1156843)

To link to this article: <http://dx.doi.org/10.1080/10803548.2016.1156843>



Accepted author version posted online: 08 Mar 2016.
Published online: 14 Apr 2016.



Submit your article to this journal [↗](#)



Article views: 13



View related articles [↗](#)



View Crossmark data [↗](#)

Ergonomics intervention on an alternative design of a spinal board

Hilma Raimona Zadry*, Lusi Susanti and Dina Rahmayanti

University of Andalas, Indonesia

A spinal board is the evacuation tool of first aid to help the injured spinal cord. The existing spinal board has several weaknesses, both in terms of user comfort and the effectiveness and efficiency of the evacuation process. This study designs an ergonomic spinal board using the quality function deployment approach. A preliminary survey was conducted through direct observation and interviews with volunteers from the Indonesian Red Cross. Data gathered were translated into a questionnaire and answered by 47 participants in West Sumatra. The results indicate that the selection of materials, the application of strap systems as well as the addition of features are very important in designing an ergonomic spinal board. The data were used in designing an ergonomic spinal board. The use of anthropometric data ensures that this product can accommodate safety and comfort when immobilized, as well as the flexibility and speed of the rescue evacuation process.

Keywords: spinal board; ergonomics; quality function deployment; product design

1. Introduction

Indonesia is one of the most disaster-prone countries in the world. The country faces multiple hazards such as earthquake, tsunami, volcanic eruption, flood, landslide, drought and forest fire. Data from the United Nations International Strategy for Disaster Reduction (UN-ISDR) mention that in terms of human exposure or the number of people present in hazard zones who may lose their lives due to a hazardous event, Indonesia is the top rank for natural disasters with many people exposed.[1] Moreover, the latest data released by the World Health Organization (WHO) show that Indonesia is the fifth country in the world with the highest number of deaths from traffic accidents. Indonesia also ranks first in the increase of traffic accident numbers by more than 80%. In Indonesia, the death toll from traffic accidents reached 120 people per day (0.02% population) and most of the people who were killed in road accidents were riders of two-wheel or three-wheel vehicles, which is about 61%.[2] Therefore, Indonesia must have a good standard of care for the impact of natural disasters and traffic accidents.

One of the common injuries as a result of disasters and traffic accidents is spinal cord injury. Spinal cord injury can result in long-term disability, often with profound effects on the quality of life of the affected individuals and their carers.[3] Injury or damage to the central nervous system on a larger scale can result in permanent paralysis and death. The National Spinal Cord Injury Statistical Centre (NSCISC) collected epidemiological data in the USA from 2010 to 2012 on the cause of injury to the spinal nervous

system. The data show that the most common cause of traumatic injury to the spinal nervous system, among others, is because of motor vehicle accidents at 36.5%, falls from a height at 28.5%, an intentional act of violence at 14.3%, sports at 9.2% and other unknown causes at 11.4%.[4] Mortality (risk of death) in victims with traumatic spinal cord injury is estimated at 48% in the first 24 h, and approximately 80% died at the scene.[5] This shows that effective and efficient handling should reduce the risk of injury or the victim's death at critical times. One factor that should be maintained for saving lives is victim first aid and evacuation itself, by knowing the proper technique for moving the victims to a safer area to minimize secondary injury that occurs as a result of the evacuation process itself.

Pre-hospital spinal immobilization is one of the most frequently performed procedures for trauma patients in the field. It aims to stabilize the spine by restricting mobility, thus preventing exacerbation of spinal cord injury during extrication, resuscitation, transport and evaluation of trauma patients with suspected spinal instability.[6] When spinal injury is suspected, patient extraction and transportation to the hospital must prevent deterioration or damage and ensure protection of the spine. Any equipment used must be light, easy to use and assemble, to a degree comfortable for the patient and fit securely in the back of the ambulance. In addition, it must also be strong and supportive enough to carry the weight of an adult.[7]

In Indonesia, the rigid long spinal board is found in every emergency ambulance and is the primary piece of equipment used to extract, carry and support the patient

*Corresponding author. Email: hilma@ft.unand.ac.id

with spinal injury en route to the hospital. This tool is shaped like an emergency stretcher board and made from wood or polymer with a flat surface that is used to perform the evacuation of the injured spine. The basic principle use of a spinal board is to immobilize (limiting the space of) the position of the spine so that the injury to the spine due to swinging, clashing or shocks that occur during the evacuation process can be minimized. The important role of the spinal board in the pre-hospital phase is undeniable.[7] This method of immobilization is well established in pre-hospital and in-hospital trauma protocols.[8,9]

In practice, however, the existing spinal board has several shortcomings, both in terms of user comfort and also effectiveness and efficiency of the evacuation process. In fact, a previous study found that the use of a spinal board can cause pain, discomfort in victims and respiratory disorders.[10] Furthermore, a spinal board can decrease tissue perfusion (blockage of the flow of oxygen in the tissue capillaries) at the points given pressure (in this case the placement of ropes or strap), which will lead to occurrence

of a decubitus wound, a wound caused by blockage of blood flow on certain body parts.[9,11] Table 1 presents the methods and results of those studies claiming that a spinal board has negative effects on human health.

There is a large body of research addressing the ergonomic risks associated with patient handling among health care workers, almost all of which has been conducted on nursing personnel.[12–15] There has also been research on the physical demands associated specifically with emergency medical services (EMS) worker job tasks.[16–19] Many studies were also found on the effect of the spinal immobilization devices on patients' health.[6,11,20–22] Some previous research discussed the comparison between a spinal board and other related devices.[23–28] Table 2 presents the results of this comparison.

The comparison shows that the spinal board has strengths and weaknesses compared with the other tools. These results can be used as a reference for designing better spinal boards. Moreover, very few researchers have

Table 1. Previous studies about the effect of the spinal board on human health.

Author	Objective	Method	Result
Kwan and Bunn [6]	To evaluate the effects of spinal immobilization on healthy participants.	A systematic review of randomized, controlled trials of spinal immobilization on healthy participants.	For immobilization efficacy, collars, spinal boards, vacuum splints and abdominal/torso strapping provided a significant reduction in spinal movement. Adverse effects of spinal immobilization included a significant increase in respiratory effort, skin ischemia, pain and discomfort.
Chan et al. [10]	To determine the effects of standard spinal immobilization on a group of healthy volunteers with respect to induced pain and discomfort.	<ul style="list-style-type: none"> • Participants were 21 healthy volunteers with no history of back disease. • Subjects were placed in standard backboard immobilization for a 30-minute period. • Number and severity of immediate and delayed symptoms were determined. 	<ul style="list-style-type: none"> • All participants developed pain within the immediate observation period. • Occipital headache and sacral, lumbar and mandibular pain were the most frequent symptoms.
Bauer and Kowalski [11]	To test the effect of the ZED board and spinal board with criss-crossing straps across the thorax on pulmonary function.	<ul style="list-style-type: none"> • Study participants were 15 male volunteers, 23–28 years old who had no history of recurrent respiratory disease, heart disease or current respiratory symptoms and who were non-smokers. • Pulmonary functions were measured with a Breon spirometer. • Measurements included FVC, FEV in 1s (FEV₁), FEF 25–75% and the FEV₁:FVC ratio. 	Long spinal board and the ZED board used for spinal immobilization have restrictive effects on pulmonary function in the healthy, non-smoking man.

Note: FEF = forced mid-expiratory flow; FEV = forced expiratory volume; FVC = forced vital capacity; ZED = Zee Extrication Device.

Table 2. Comparison between a spinal board and other related devices based on previous studies.

Author	Objective	Comparison result	
		Spinal board	Other EMS devices
Lovell and Evans [23]	To evaluate the differences between the spinal board and the vacuum stretcher in pressure characteristics of these two support surfaces.	The mean sacral interface pressure on a spinal board (147.3 mmHg) is above average systolic blood pressure (120 mmHg). No support was given to the normal lumbar lordosis by the spinal board.	The mean sacral interface pressure was dramatically reduced with the vacuum stretcher (36 mmHg). Support was given to the normal lumbar lordosis by the vacuum stretcher.
Johnson et al. [24]	To compare a vacuum splint device with a rigid backboard with respect to comfort, speed of application and degree of immobilization.	The rigid backboard with head block was slightly better at immobilizing the head.	Vacuum splint device was significantly more comfortable, faster to apply and provided better immobilization of the torso and less slippage on a gradual lateral tilt than the rigid backboard.
Main and Lovell [25]	To evaluate seven evacuation suffer support surfaces. These included the conventional spinal board, two designs of vacuum stretcher, a prototype support surface which was a combination of both principles, and three conventional stretchers.	The spinal board has several deficiencies, including lack of support for the lumbar lordosis. It should not be the preferred surface for the transfer of patients with spinal injuries.	The best support surface of those used for spinal protection was the new vacuum stretcher, both for interface pressures and subject comfort. Of the other surfaces, the ambulance stretcher had the best result for comfort and interface pressures, although the other stretcher surfaces provided reasonable results and would be safe in the short term.
Cross and Baskerville [26]	To compare the locations and severities of pain generated by a hard wooden spinal board vs. a soft vacuum mattress splint on immobilized volunteers.	The hard spinal board had higher mean pain scores as well as a higher percentage of subjects who reported any pain when compared with the two vacuum mattress splints.	
Luscombe and Williams [27]	To compare the stability and comfort afforded by the long spinal board (backboard) and the vacuum mattress.	The mean body movements in the head-up position, head down and lateral tilt were significantly greater on the backboard than on the vacuum mattress ($p < 0.01$ for all planes of movement).	Using the NRS the vacuum mattress was significantly more comfortable than the backboard. In the measured planes the vacuum mattress provides significantly superior stability and comfort than a backboard.
Mahshidfar et al. [28]	To compare spinal immobilization using LBB with a VMS in trauma victims transported by an EMS system.	LBB was easier, faster, and more comfortable for the patient, and provided additional decrease in spinal movement when compared with a VMS.	

Note: EMS = emergency medical services; LBB = long backboard; NRS = numerical rating scale; VMS = vacuum mattress splint.

discussed the ergonomic design of pre-hospital management of trauma devices, especially those related to the spinal immobilization devices. By observing the facts, it can be concluded that it is necessary to design an alternative spinal board using an ergonomics approach. This aims to achieve mobility and better equipment compatibility when in use so that the evacuation process can be performed more effectively, efficiently and safely. By doing this, it is expected that the risk of death for victims

with traumatic injuries to the spine can be minimized, thus increasing the comfort and safety of both victims and rescuers when evacuation is done.

Regarding the methods for designing the new product development, quality function deployment (QFD) is a significant methodological approach to enhance customer satisfaction and reduce the product costs and development cycle time. It is also a crucial tool to increase time and resource savings throughout all stages – from design to

production planning.[29] QFD has been profitably applied by industries around the world.[30–32] A previous study has been conducted to identify the design requirements of an ergonomic spinal board.[33] Hence, this study used those requirements for designing an ergonomic spinal board.

2. Identification of design requirements for an ergonomic spinal board

The identification of design requirements for an ergonomic spinal board has been conducted through a preliminary study by direct observation of the actual use of the existing spinal board, interviewing and collecting questionnaires from 47 participants from medics, Red Cross, Ambulance Unit Medical Officer and the rescue team of Padang, West Sumatera.[33] The interviews were carried out with volunteers from the Indonesian Red Cross of West Sumatera to know in general how customers respond to the existing spinal board on the market nowadays as well as the characteristics of the customers towards the desired spinal board in the future. The interview results serve as a reference in designing the research questionnaire. This is also a method to gain an initial picture of customer expectations for designing an ergonomic spinal board.

The survey questionnaire was developed based on the data from the interviews. It also refers to the dimensions of quality according to Garvin [34] and ergonomics principles from product design.[35] The criteria include performance, features, durability and aesthetics. Also added is the price aspect as proposed by the American Society for Quality Control (ASQC). The questionnaire aims to investigate customer requirements and desires related to the ergonomic spinal board.

The collected data of survey questionnaires were processed using QFD design through the House of Quality (HoQ). The HoQ consists of several activities supported by various tables and matrices. The basic idea is to translate customer requirements into product design requirements in order to increase customer satisfaction.[36–38] The HoQ for the ergonomic spinal board has been developed in a preliminary study [33] using the following steps:

- Determine customer requirements and customer important ratings.
- Translate customer requirements into measurable technical requirements.
- Determine the relationship between customer requirements and technical requirements.
- Determine the interactions between technical requirements.
- Determine the priority of technical requirements.
- Determine design requirements.
- Determine the relationship between technical requirements and design requirements.
- Determine the priority of design requirements.

Figures 1 and 2 present the HoQ for the ergonomic spinal board.

3. Product design

The ergonomic spinal board was designed based on the HoQ results in Figures 1 and 2. It was designed based on the required characteristics of function, appearance, safety and assemblability. Additional features were designed in order to improve the spinal board design. Anthropometric data were then applied in the process of designing to fit the product to human use. Additional features in this product are listed in the following sections.

3.1. The spinal board is foldable

The spinal board has quite large dimensions; this is one of the deficiencies that may reduce its flexibility. Modifying the shape of the main board by dividing it into two, folded in the area under the buttocks, was the best solution to improve flexibility (Figure 3a and b).

3.2. Head immobilizer integrated with the spinal board

Generally, the head immobilizer for a spinal board is a separate device that certainly requires more time to install. Thus, in this design the head immobilizer was integrated directly into the spinal board (Figure 4).

3.3. Strap system

The system applied in the design straps is an ECS-straps system. This is a crossing restraint system for immobilization, where the safety determined by the self-adherent strip closure, the sliding of the cross-sectional belts upon the longitudinal one and the extension will allow a better fit to the victim's body. The buckle lock uses a plastic bag buckle located at the centre of the straps. Straps facing the victim's body are equipped with ethylene vinyl acetate (EVA) foam pads to reduce the risk of decubitus sores due to oxygen blockage in the tissue capillaries at the placement of the straps. The straps on the chest can also be used as thongs, and thus the spinal board in the folded state can be carried like a backpack (Figure 5).

3.4. Main board material

High-density polyethylene (HDPE) was used in designing the main board because of its strength. However, polyurethane was used inside the board to reduce the overall weight of the spinal board.

3.5. Anthropometric data used

For the ergonomic design of the spinal board, the anthropometric data are a prerequisite. In this research, the product

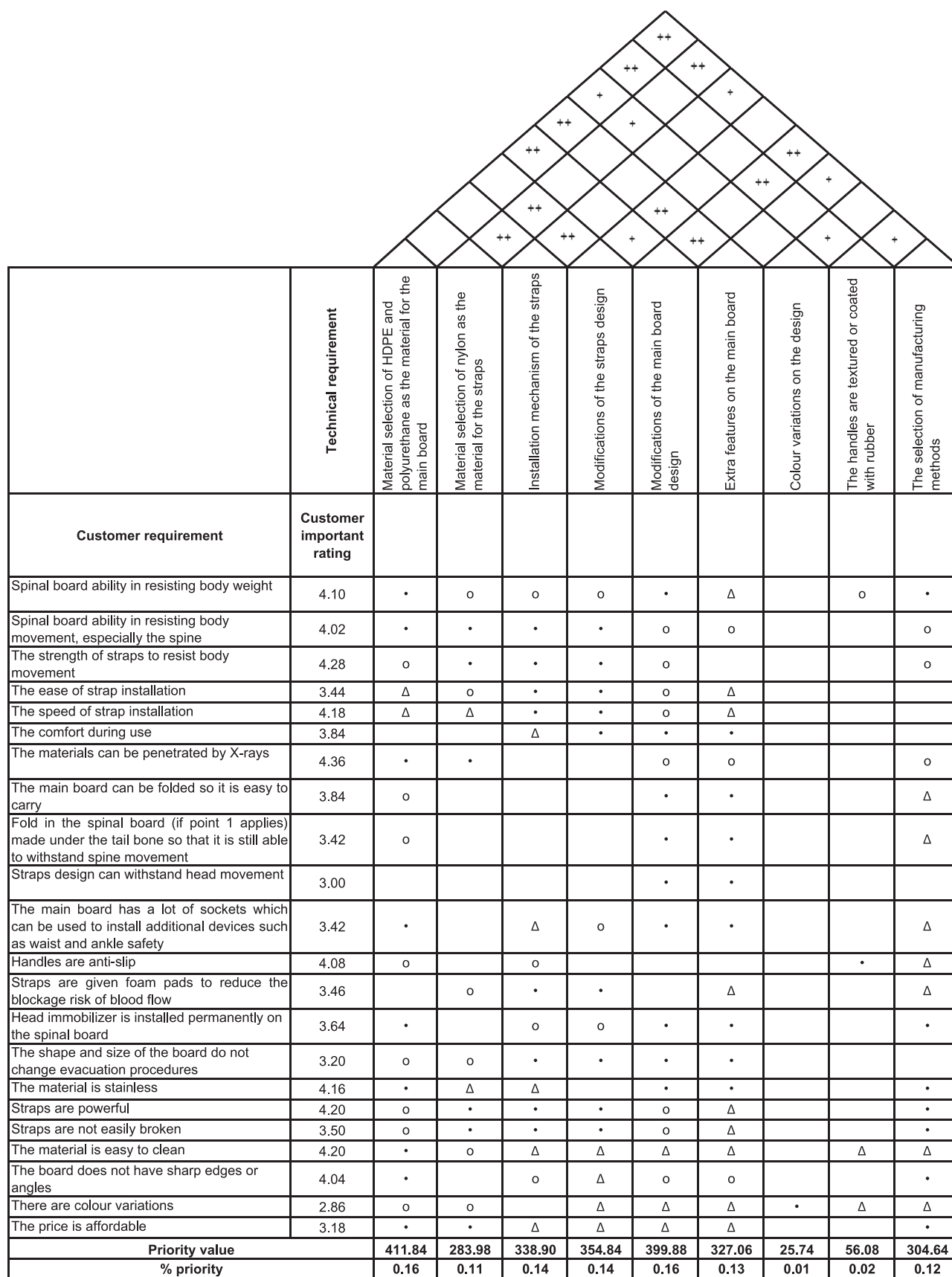

Figure 1. House of quality phase I: the relationship between customer requirements and technical requirements. Note: empty = no relationship (0); Δ = weak (1); o = moderate (3); • = strong (9); + = medium positive relationship; + + = strong positive relationship.

Technical requirement	Important rating	The average thickness of HDPE outer layer is 0.50-0.75 cm	The main board, hinges and handles are moulded from solid HDPE without polyurethane injection	Head immobilizer is moulded from HDPE and polyurethane	Folds use projection hinge system with a maximum rotation of 180°	Folds equipped with a locking hinge	Head immobilizer can be rotated 90° when used	ECS-strap system used without vertical safety rope and head safety rope	Lock on the straps is mounted in the middle	Velcro tape is used as the straps lock on the head immobilizer	Plastic bag buckle is used as the lock on the ECS straps	Head immobilizer is fitted with foam pads	The main board equipped with socket on the bottom of locomotor	The main board is made using injection molding process	Mounting hinge uses screw system	Nylon webbing is used with 4cm width and 0.25cm thickness	Rough and rubber textures are applied on the grip of the main board	Color variations on the main board	Color variations on the strap systems
Material selection of HDPE and polyurethane as the material for the main board	411.84	•	•	•	•	•	o			Δ		o	o	•	o			o	
Modifications of the main board design	399.88	•	•	•	•	•	•	o	Δ	o	o	•	•	•	o		o	•	
Modifications of the straps design	354.84						o	•	•	•	•		Δ			•			•
Installation mechanism of the straps	338.9							•	•	•	•		Δ			•			•
Extra features on the main board	327.06	•	Δ	•	•	•	•	•	o	•	o	•	•	•	o	o	•	•	o
Material selection of nylon as the material for the straps	304.64							•	•	•	•					•			•
The selection of manufacturing methods	283.98	•	•	•	o	o		Δ	Δ	o	o		Δ	•	•	o		Δ	
The handles are textured or coated with rubber	56.08		Δ														•		
Colour variations on the design	25.74	Δ	Δ	Δ			Δ	o	Δ	Δ	Δ	Δ		•		o	o	•	•
Priority value		12831	10270	12831	11101	11101	8868.2	13490	10676	14418	12044	7803.7	8755.7	13037	5972.2	10896	4725.1	8293.6	10198
% priority		0.07	0.05	0.07	0.06	0.06	0.05	0.07	0.06	0.08	0.06	0.04	0.05	0.07	0.03	0.06	0.03	0.04	0.05

Figure 2. House of quality phase II: the relationship between technical requirements and design requirements. Note: HDPE = high-density polyethylene; empty = no relationship (0); Δ = weak (1); o = moderate (3); • = strong (9).

was designed using anthropometric data of the Indonesian population aged 15–64 years. Figure 6 shows the anthropometric dimensions used in the design and Table 3 presents the data.

The application of anthropometric data is discussed in the following sections.

3.5.1. Hand-hold slot

The hand-hold slot dimension was design based on the grip diameter, hand breadth and hand thickness dimensions. The 5th percentile value of the grip diameter was used as the hand grip size, which is equal to 4.40 cm, while the 95th percentile value of hand breadth (10.20 cm) was used as the handle length. Taking the clearance as 4 cm on each side of the grip, the handle length comes to 14.20 cm and this value is recommended for the handle length. The clearance aims to facilitate the user’s hand position as well as to provide an area for the strap clips to tie the straps to the board. The 95th percentile value of hand thickness was then used as the space to insert fingers (slot) into the handle. The value is 4.13 cm after adding 1 cm as the clearance.

3.5.2. Main board length

The main board was designed so that it can be folded into two parts, the top and bottom folds. The length of the top fold was determined based on the dimensions

from the top of the head into the fingertip height (the 95th percentile value of stature dimension minus the 95th percentile value of fingertip height: 166.99 cm – 62.10 cm = 104.89 cm). This percentile was chosen to accommodate an extremely tall accident victim. The value was added to the hand grip size (4.40 cm) and the finger slot (4.13 cm). The length of the top fold becomes 104.89 cm + 4.40 cm + 4.13 cm = 113.42 cm.

The length of the bottom fold was determined based on the 95th percentile value of fingertip height (62.10 cm). This was added to the hand grip size (4.40 cm) and the finger slot (4.13 cm). The length of the bottom fold becomes 62.10 cm + 4.40 cm + 4.13 cm = 70.63 cm. Thus, the overall length of the main board was 113.42 cm + 70.63 cm = 184.05 cm.

3.5.3. Main board width

The main board width of the top fold was determined from the 95th percentile of shoulder breadth (45.51 cm). The width of the bottom fold was designed to taper at the foot end to facilitate the immobilization process and to strengthen the bond straps on the bottom of the victim’s body. To that end, the width of the bottom main board was derived from the 95th percentile value of foot breadth (10.76 cm). It was multiplied by 2 to accommodate the victim’s feet (2 × 10.76 cm = 21.52 cm). Taking the

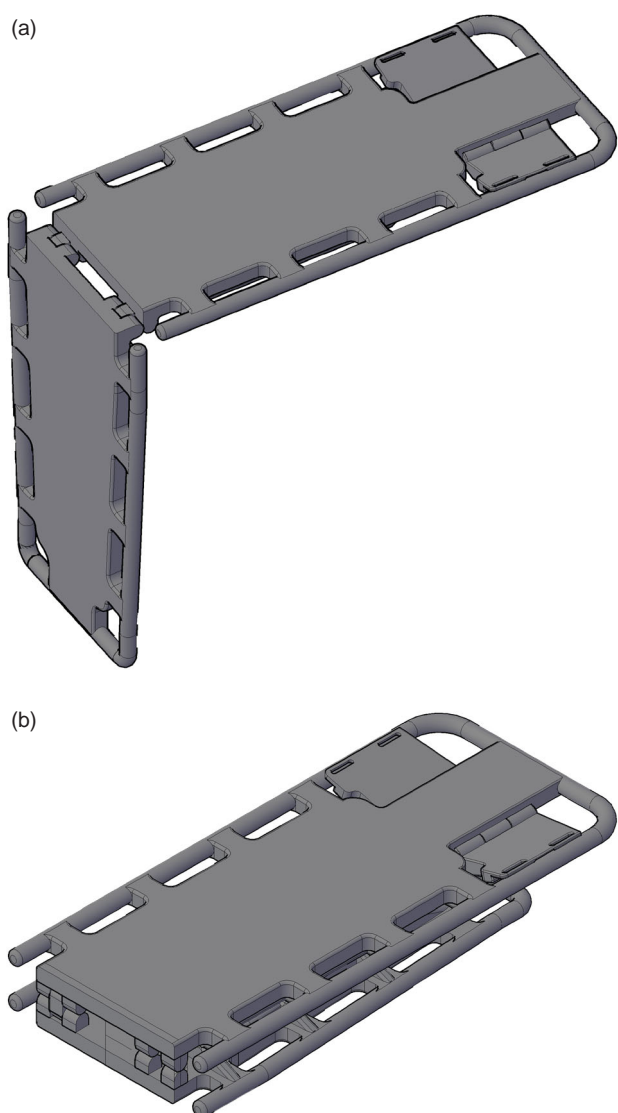

Figure 3. Fold in the spinal board.
Note: (a) Spinal board in the unfolded state; (b) Spinal board in the folded state.

clearance for handle size (hand grip and finger slot) on the right and left sides ($2 \times 8.53 \text{ cm} = 17.06 \text{ cm}$) resulted in the width of the main board at the foot end being 38.58 cm ($21.52 \text{ cm} + 17.06 \text{ cm}$).

3.5.4. Head immobilizer size

The head immobilizer length was derived from the difference between the 95th percentile values of stature and shoulder height dimensions ($166.99 \text{ cm} - 127.18 \text{ cm} = 39.81 \text{ cm}$). On the other hand, the width of the head immobilizer was based on the 95th percentile value of head breadth added to 2 cm clearance ($13.70 \text{ cm} + 2 \text{ cm} = 15.70 \text{ cm}$). The head immobilizer was also equipped with foam pads made from EVA with a thickness on each side of 3 cm to accommodate victims with small dimensions.

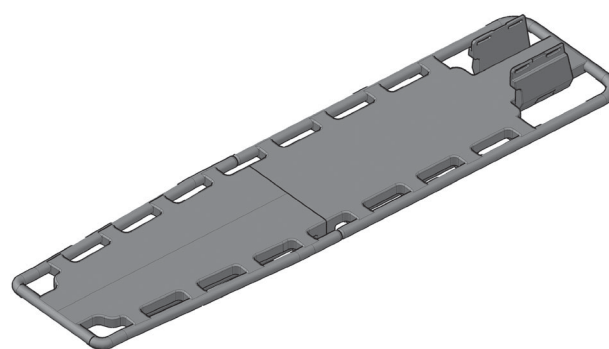

Figure 4. Head immobilizer.



Figure 5. Spinal board strap system.

4. Discussion

Important customer ratings show that the highest requirements for the spinal board design according to the customers are the selection of main board materials, the application of spinal board strap systems as well as the addition of spinal board features. The variable that gets the highest rating is 'The materials can be penetrated by X-rays' with the rating value of 4.36 or classified as 'important'. This is because the victim should be immobilized well until the scanning process using X-rays is completed. Transfer of the victim without an immobilization tool will increase the risk of secondary injury.

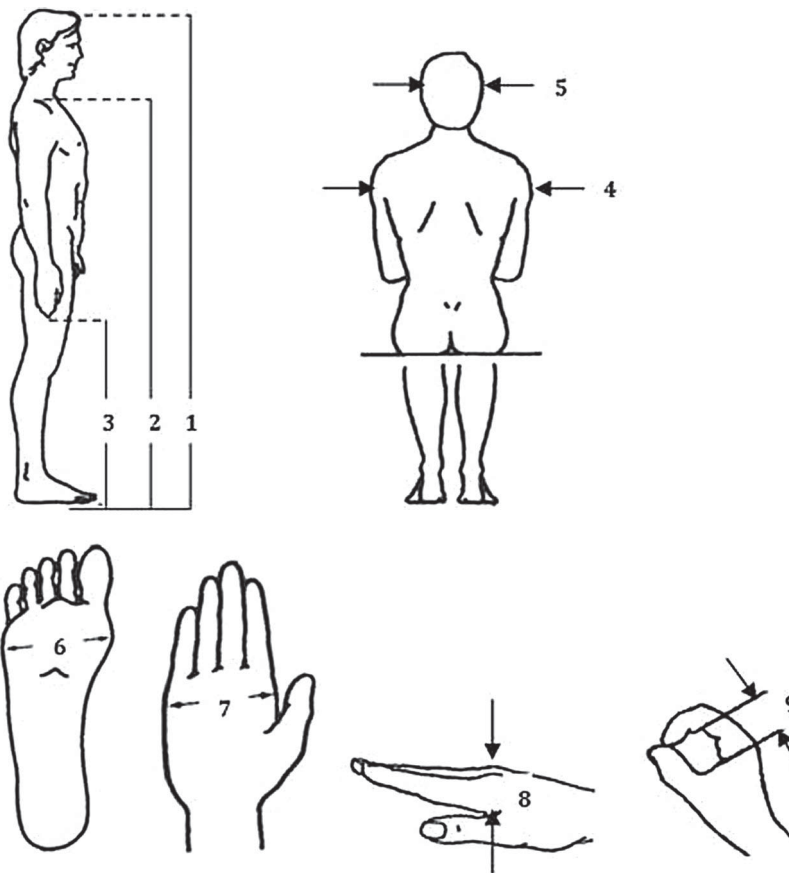

Figure 6. Anthropometric dimensions.

Note: 1 = stature; 2 = shoulder height; 3 = fingertip height; 4 = shoulder breadth; 5 = head breadth; 6 = foot breadth; 7 = hand breadth; 8 = hand thickness; 9 = grip diameter.

Table 3. Anthropometric dimensions (cm) of the Indonesian population.

Number	Dimension	Percentile			SD
		5th	50th	95th	
1	Stature	163.70	165.34	166.99	8.07
2	Shoulder height	123.89	125.54	127.18	19.01
3	Fingertip height	58.81	60.45	62.10	12.76
4	Shoulder breadth	42.22	43.86	45.51	7.16
5	Head breadth	10.41	12.05	13.70	3.15
6	Foot breadth	7.47	9.12	10.76	1.80
7	Hand breadth	8.50	9.35	10.20	0.20
8	Hand thickness	2.30	2.68	3.13	0.24
9	Grip diameter (inside)	4.40	4.70	5.00	0.20

Note: Shading indicates the percentile used for design.

Polyethylene and polyurethane are the best options to be used as the main board material because of their ability and endurance. Those materials can also answer the fourth rating ‘Spinal board material is easy to clean’ and the sixth rating ‘Spinal board material is stainless’. This is because polyethylene and polyurethane are thermoplastic materials with small pores so they do not absorb water and can survive at extreme temperatures.

In terms of strength, polyethylene – especially HDPE – has good strength because it has a high density equal to 0.941 g/cm^3 , with an average tensile strength of 32 MPa.[39] It can answer the customer requirement on the seventh rating ‘Spinal board ability in resisting body weight’. Therefore, the parts which have the important function of weight-bearing on the main board – such as the bottom frame, hinges, connecting pegs and side handles – are made using rigid HDPE, while at the top of the main board HDPE is used as the outer shell with polyurethane on the inside. This can reduce the overall weight of the spinal board, but will not affect its strength.

The next highest customer requirements are related to the strap system. They include ‘The strength of straps to resist body movement,’ ‘Spinal board straps are powerful’ and ‘The speed of strap installation’. This shows that the selection and application of a strap system which is strong and has quick installation are important for the customers. Therefore, an ECS-straps system with nylon will be used to design the straps in the product. ECS-straps are a crossing restraint system for both adults and children and can be used on a variety of transport devices such as boards and vacuum mattresses. The sliding of the cross-sectional belts upon the longitudinal one and its extension

will allow a better fit to the victim's body. All of these features make ECS-straps an innovative and versatile device for any kind of immobilization operation.[40] This system makes a bond not rely on a single point only, so the risk of rope cut-off is smaller. By implementing this system, the emphasis on the body will be split between two segments of the rope so that the risk of blood blockage is also smaller.

In terms of feature development, customers require 'Spinal board handles are anti-slip' with a rating value of 4.08, 'The main board can be folded so it is easy to carry' with a value of 3.84 and 'Head immobilizer is installed permanently on the spinal board' with a value of 3.64. These features are then implemented in the design. To the side grip on the main board, the handles have a circular shape so that rescuers can grasp the board perfectly. The texture on the grip is also made rougher so that the risk of slip is smaller when gripped. At the top of the board are also added head immobilizer features integrated on the main board so that the victim's head can be detained without any additional devices and the evacuation process can be faster. The spinal board can be folded into two parts to increase the rescuers' flexibility when carrying it. All components including the hinges player in the crease and the head immobilizer are made from the same material as the main board. They can therefore still be penetrated by X-rays but do not reduce the strength and resilience of the spinal board.

In terms of product design performance, the spinal board was designed to meet consumer needs. The product was modified in the shape and dimensions of the main board, the shape and the application of the strap system, and then the addition of some features to support the spinal board. The following is a description of each modification:

- Modifications of the shape and dimensions of the main board. On the main board, modifications were carried out on some parts, such as side grip shape, main board framework, main board materials as well as application of a fold on the main board. On the handle side, the diameter of the handle is determined based on anthropometry data. Therefore, the rescuers can grasp the spinal board well and improve the safety of spinal board use. The size of the cavity is also made larger so as to enable rescuers' fingers to be easily inserted under the patient's body. The flexibility is also enhanced by applying the fold hinged in the middle of the board. The fold was made under the buttocks so that the spinal cord has been supported by the top of the board.
- Modifications of the strap system. As already explained, the strap system applied to the design is the ECS-straps system. The straps are crossed on three parts of the body: chest, waist and legs. For ease of installation, the straps are equipped with a bag buckle. The bag buckle is integrated on one

segment of the straps in the middle of the binder that can be adjusted in length according to needs. The use of a bag buckle also allows rescuers to bring the board in the folded state using a backpack so that the spinal board would be more practical when being transported. In addition, to increase the patient's comfort the strap in direct contact with the patient's body is given EVA foam pads so the patient's skin will not be scratched.

- Additional features. Additional features implemented in this design are giving texture to the spinal board grip as well as the head immobilizer, which is integrated directly into the main board. The head immobilizer will certainly save on the evacuation time. In addition, the presence of EVA foam pads on the inside of the head immobilizer will accommodate the head of the patient with extreme dimensions.

This ergonomics study focused on efforts to achieve a design that meets 'fitting the task to the man'. Ergonomics studies leading to the benefit of man do not merely lead to the technical or functional aspects of the product. The design of the spinal board in this study accommodates the two sides' interests of users, such as safety and comfort when immobilized, as well as the rescuers, such as flexibility and speed of the rescue evacuation process. The use of anthropometric variables was also adjusted to the dimensions of the Indonesian population, for which it is expected that this product is really targeted to help efforts in controlling accidents and disasters in Indonesia.

5. Conclusion

This study has succeeded in making an alternative design of spinal board to increase the effectiveness and efficiency of the existing spinal board products. The design was made in accordance with customer requirements and consultancy with experts using the QFD method. The results indicate that the selection of spinal board materials, the application of strap systems as well as the addition of spinal board features are very important to design an ergonomic spinal board. The improvement of product design includes the following:

- Application of HDPE and polyurethane on the main board.
- Head immobilizer integrated into the main board.
- The strap system is modified by implementing the ECS-straps system, which is equipped with a bag buckle to increase the speed of the installation process.
- Addition of a fold under the buttocks on the main board.

The next phase of the study will discuss part deployment until production planning. The ergonomic spine

board can thus be designed in accordance with the conditions and the latest technology.

Disclosure statement

No potential conflict of interest was reported by the authors.

Funding

This work was supported by Directorate General for Higher Education of Indonesia under grant Penelitian Unggulan Perguruan Tinggi [No. 44/UN.16/UPT/LPPM/2015].

References

- [1] AIPA. Indonesia's country report on disaster response management. ASEAN Inter-Parliamentary Assembly, 3rd AIPA CAUCUS; 2011, 31 May – 3 June, Manila, Philippines.
- [2] World Health Organization. Global status report on road safety 2013: supporting a decade of action: summary. 2013.
- [3] Kwan I, Bunn F, Roberts IG. Spinal immobilisation for trauma patients. The Cochrane Library. London: Wiley; 2009.
- [4] National Spinal Cord Injury Statistical Center (NSCISC). Spinal cord injury facts and figures at a glance. Birmingham (AL): NSCISC; 2013.
- [5] Evans T, Brown H. Road traffic crashes: operationalizing equity in the context of health sector reform. *Int J Inj Contr Saf Promot.* 2003;10(1–2):11–12.
- [6] Kwan I, Bunn F. Effects of prehospital spinal immobilization: a systematic review of randomized trials on healthy subjects. *Prehos Disaster Med.* 2005;20(1):47–53.
- [7] Stagg MJ, Lovell ME. A repeat audit of spinal board usage in the emergency department. *Injury.* 2008;39(3):323–326.
- [8] American College of Surgeons Committee on Trauma. Advanced trauma life support for doctors. 7th ed. Chicago (IL): American College of Surgeons; 2004.
- [9] [no authors listed] EMS spinal precautions and the use of the long backboard. *Prehosp Emerg Care.* 2013;17(3):392–393.
- [10] Chan D, Goldberg R, Tascone A, et al. The effect of spinal immobilization on healthy volunteers. *Ann Emerg Med.* 1994;23(1):48–51.
- [11] Bauer D, Kowalski R. Effect of spinal immobilization devices on pulmonary function in the healthy, nonsmoking man. *Ann Emerg Med.* 1988;17(9):915–918.
- [12] Hignett S. Systematic review of patient handling activities starting in lying, sitting and standing positions. *J Adv Nurs.* 2003;41:545–552.
- [13] Bos EH, Krol B, Van Der Star A, et al. The effects of occupational interventions on reduction of musculoskeletal symptoms in the nursing profession. *Ergonomics.* 2006;49(7):706–723.
- [14] Waters T, Collins J, Galinsky T, Caruso C. NIOSH research efforts to prevent musculoskeletal disorders in the healthcare industry. *Orthop Nurs.* 2006;25(6):380–389.
- [15] Arsalani N, Fallahi-Khoshknab M, Josephson M, et al. Musculoskeletal disorders and working conditions among Iranian nursing personnel. *Int J Occup Saf Ergon.* 2014;20(4):671–680. doi:10.1080/10803548.2014.11077073.
- [16] Lavender SA, Conrad KM, Reichelt PA, Gacki-Smith J, Kohok AK. Designing ergonomic interventions for EMS workers, part I: transporting patients down the stairs. *Appl Ergon.* 2007;38(1):71–81.
- [17] Lavender SA, Conrad KM, Reichelt PA, et al. Designing ergonomic interventions for EMS workers – part II: lateral transfers. *Appl Ergon.* 2007;38(2):227–236.
- [18] Lavender SA, Conrad KM, Reichelt PA, et al. Designing ergonomic interventions for emergency medical services workers—part III: bed to stairchair transfers. *Appl Ergon.* 2007;38(5):581–589.
- [19] Conrad KM, Reichelt PA, Lavender SA, et al. Designing ergonomic interventions for EMS workers: concept generation of patient-handling devices. *Appl Ergon.* 2008;39(6):792–802.
- [20] Hauswald M, Hsu M, Stockhoff C. Maximizing comfort and minimizing ischemia: a comparison of four methods of spinal immobilization. *Prehosp Emerg Care.* 2000;4(3):250–252.
- [21] Mok JM, Jackson KL, Fang R, et al. Effect of vacuum spine board immobilization on incidence of pressure ulcers during evacuation of military casualties from theater. *Spine J.* 2013;13(12):1801–1808.
- [22] Oomens CWJ, Zenhorst W, Broek M, et al. A numerical study to analyse the risk for pressure ulcer development on a spine board. *Clin Biomech (Bristol, Avon).* 2013;28(7):736–742.
- [23] Lovell ME, Evans JH. A comparison of the spinal board and the vacuum stretcher, spinal stability and interface pressure. *Injury.* 1994;25(3):179–180.
- [24] Johnson DR, Hauswald M, Stockhoff C. Comparison of a vacuum splint device to a rigid backboard for spinal immobilization. *Am J Emerg Med.* 1996;14(4):369–372.
- [25] Main PW, Lovell ME. A review of seven support surfaces with emphasis on their protection of the spinally injured. *J Accid Emerg Med.* 1996;13(1):34–37.
- [26] Cross DA, Baskerville J. Comparison of perceived pain with different immobilization techniques. *Prehosp Emerg Care.* 2001;5:270–274.
- [27] Luscombe MD, Williams JL. Comparison of a long spinal board and vacuum mattress for spinal immobilisation. *Emerg Med J.* 2003;20(5):476–478.
- [28] Mahshidfar B, Mofidi M, Yari AR, et al. Long backboard versus vacuum mattress splint to immobilize whole spine in trauma victims in the field: a randomized clinical trial. *Prehosp Disaster Med.* 2013;28(5):462–465.
- [29] Shil NC, Ali MA, Paiker NR. Robust customer satisfaction model using QFD. *Int J Prod Qual Manag.* 2010;6(1):112–136.
- [30] Bergman BKB. Quality from customer needs to customer satisfaction. London: McGraw-Hill; 1994.
- [31] Geum Y, Kwak R, Park Y. Modularizing services: a modified HoQ approach. *Comput Ind Eng.* 2012;62(2):579–590.
- [32] Vezzetti E, Moos S, Kretli S. A product lifecycle management methodology for supporting knowledge reuse in the consumer packaged goods domain. *Comput Aided Des.* 2011;43:1902–1911.
- [33] Zadry HR, Rahmayanti D, Susanti L, et al. Identification of design requirements for ergonomic long spinal board using Quality Function Deployment (QFD). *Procedia Manufacturing.* 2015;3:4673–4680.
- [34] Garvin DA. Managing quality: the strategic and competitive edge. New York (NY): Free Press; 1988.
- [35] Zhang F, Yang M, Liu W. Using integrated quality function deployment and theory of innovation problem solving approach for ergonomic product design. *Comput Ind Eng.* 2014;76:60–74.

- [36] Marsot J. A methodological tool for integration of ergonomics at the design stage. *Appl Ergon.* 2005;36(2): 185–192.
- [37] Lai X, Xie M, Tan KC, Yang B. Ranking of customer requirements in a competitive environment. *Comput Ind Eng.* 2008;54:202–214.
- [38] Raharjo H, Brombacher AC, Xie M. Dealing with subjectivity in early product design phase: a systematic approach to exploit quality function deployment potentials. *Comput Ind Eng.* 2008;55:253–278.
- [39] Peacock A. *Handbook of polyethylene: structures, properties, and applications.* New York (NY): Dekker; 2000.
- [40] BCAS_BIOMED: spineboard straps [Internet]. High Wycombe: BCAS_BIOMED; [cited 2015 Apr 5]. Available from: <http://www.bcasbiomed.co.uk/products-page/spencer/spineboard-straps/>.